



Delivering Separation & Process Technology

[www.chemdistgroup.com](http://www.chemdistgroup.com)

# Team



## **Director & Co-Founder**

**Dr. Sunil Dhole**

PhD (Chemical Engineering), IIT Kanpur

### **Panel Member**

- Board of Director at Water Quality India Association
- Committee Member of Bureau of “Indian Standard for Community Water Purifier”



## **Director & Co-Founder**

**Tushar Wagh**

MBA, Chemical Engineering



## **Mentor**

**Prof. J. B. Joshi (Padma Bhushan Awardee)**

- International Member of the National Academy of Engineering of the United States of America
- Emeritus Professor of Eminence, ICT

# Chemdist Expertise

Process Equipments

Process Technology

Mass Transfer Internals

Membrane Systems

Engineering Services

Turn-Key Plants



R&D



Design



Engineering



Supply



commissioning

# Capabilities



Science, Technology and Engineering Solutions



Turnkey Plants and Systems



Pilot Plants and Trials Setup



Technical Capabilities



Design and Engineering Capabilities



Inhouse Manufacturing Capabilities



Project Commissioning



Inspection and Quality Control



ISO 9001 : 2015 TUV Certified



# Infrastructure

- 3 Fabrication Units
- 80,000 Sq. Ft. Area

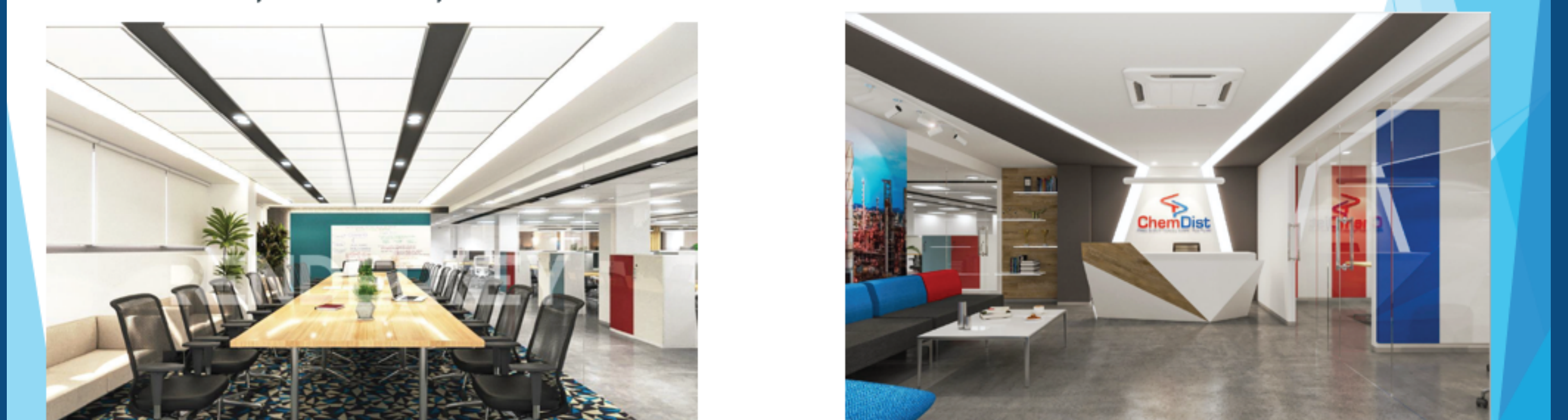

## Team & Facilities

- 80+ Engineering Professionals
- 200+ Man Power



## Corporate Office Pune

Plot No 174/1, J-Block, MIDC Bhosari, Pune - 26,  
Maharashtra, India

## Corporate Office UK

BOHO One, Bridge Street West,  
Middlesbrough, Tees Valley, TS2 1AE.

# Products & Technologies

## Technologies

- Distillation Technology
- Heat Transfer Technology
- Evaporation Technology
- Reaction & Mixing Technology
- Liq-Liq Extraction Technology
- Chemical Process Technology
- Oil & Gas Technology
- Environmental Technology
- Microreactor Technology

## Technologies

- Ethanol to Ethyl Acetate + Green Hydrogen
- Ethanol to Acetic Acid + Green Hydrogen
- Ethanol to Bio-Aviation fuel + Green Hydrogen
- Waste CO<sub>2</sub> to Nano-Urea
- Biomass to Green Plastic (PEF)
- Ammonia Cracking to Hydrogen (low temp/pressure, no NOx generation)
- Methanol Cracking to Hydrogen and Formic acid (No CO and CO<sub>2</sub> generation)
- Glycerol to Polylactic Acid (PLA) + Green Hydrogen
- Methanol Fuel Cell

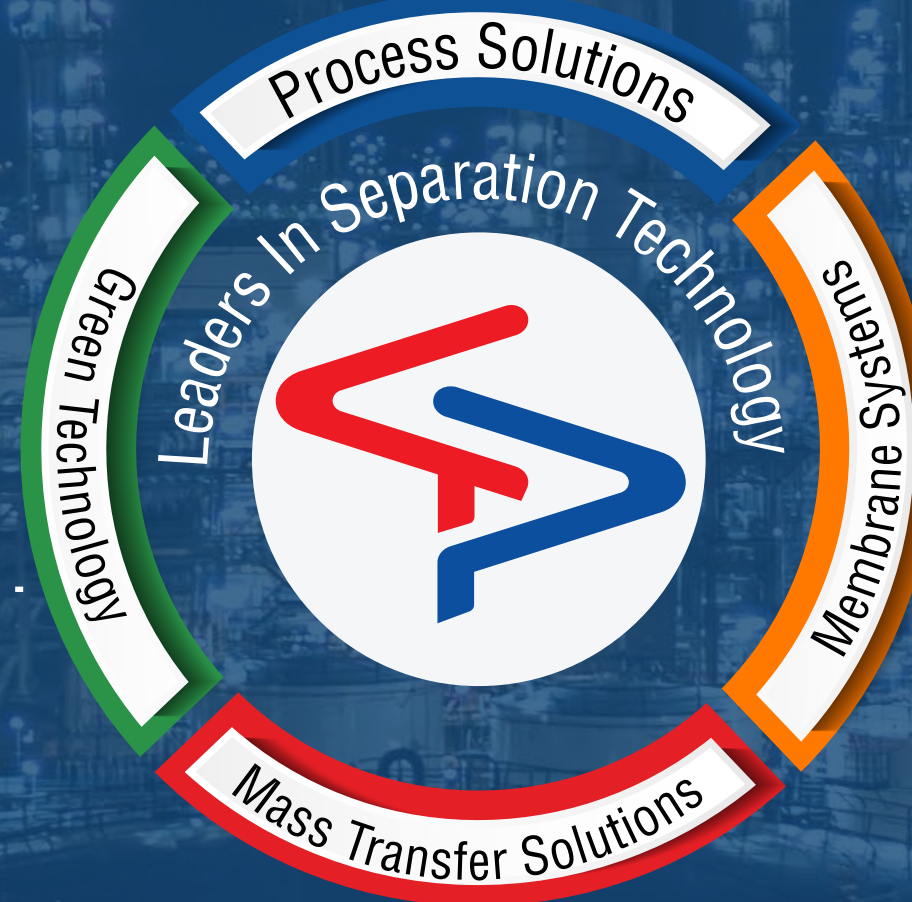

## Products

- Distillation Columns
- Heat Exchangers
- Condenser
- Reboiler
- Reactors & Agitators
- Pressure Vessel
- Static Mixers
- Thin Film Evaporator
- Wiped Film Evaporator
- Falling Film Evaporator
- Forced Circulation Evaporator
- Strippers
- Scrubbers
- Skids

## Technologies

- ZLD- Membrane Distillation
- Membrane Pervaporation
- Oxygen Concentration Technology
- Ultrafiltration Membrane
- Membrane Decanter

## Products

### Mass Transfer Products

- Structured Packings
- Random Packing
- Trays
- Liquid Distributor
- Liquid Collector
- Packing Support

# Distillation Technology - Turn-Key Plants

---



## Types Of Distillation Columns

---

- Batch Distillation
- Continuous Distillation
- Multipurpose Solvent Recovery Systems
- Azeotropic Distillation
- Extractive Distillation
- Vacuum Distillation
- Divided Wall Column Distillation
- Pilot Distillation Systems

# Distillation Columns

---



**Dia 4.2 m and 67 m Height**



# Mass Transfer Internals

---

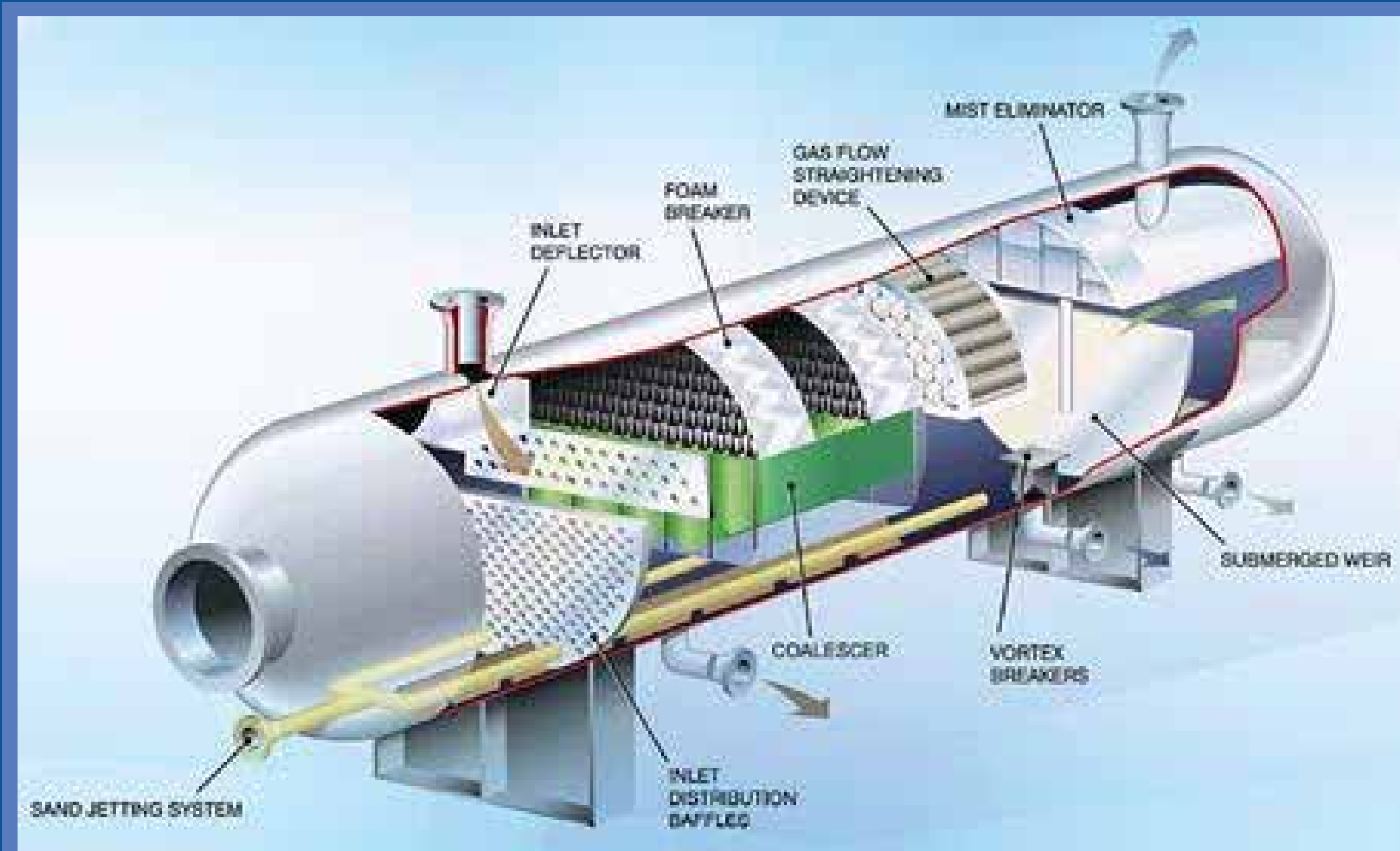

## Mass Transfer Internals

---

- Structured Packings
- Random Packings
- Trays
- Liquid distributor
- Liquid Collector
- Packing Support
- Demisters
- Static Mixers
- Separator Internals

# Structured Packings



# Random Packings



# Trays

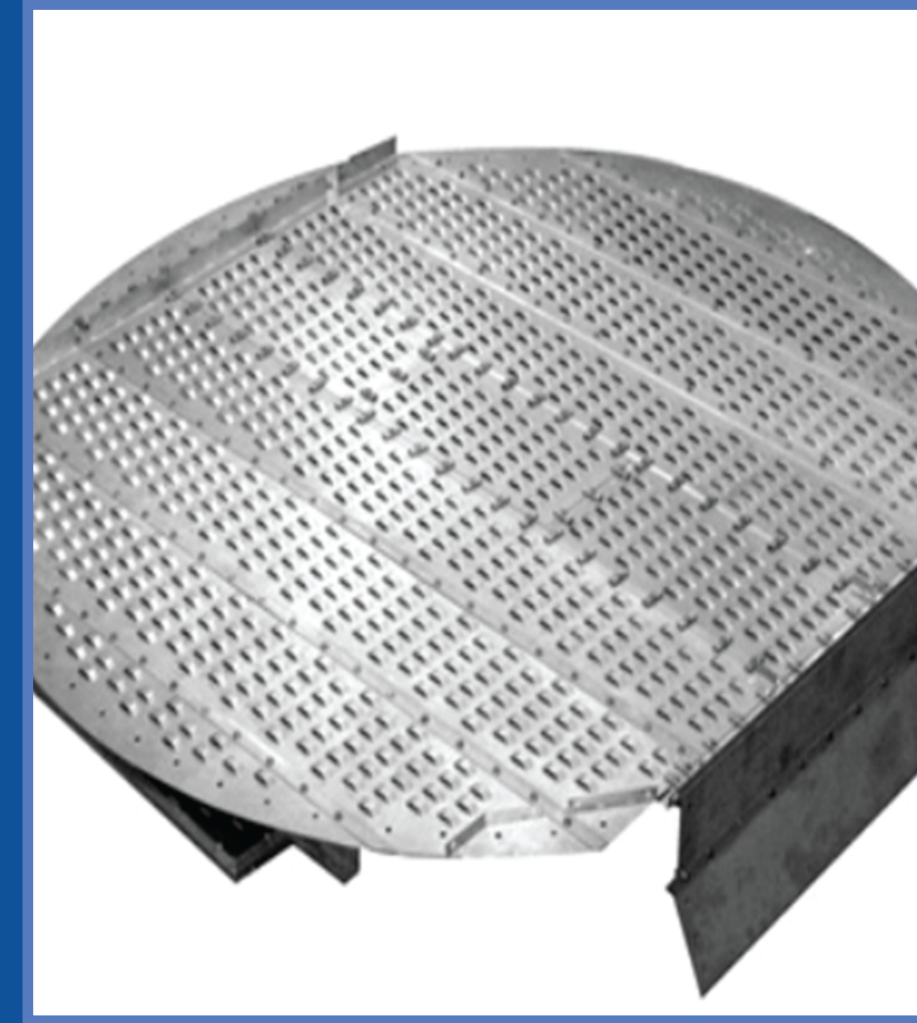

# Internals



# Static Mixer

MOC: SS304, SS304L, SS316, SS316L, SS904L, SS317L, Hastelloy-C-276, Alloy 20, Duplex, titanium, 316Ti.

LINING: PTFE, FRP, PP, PFFRP, PVC



CMV Static Mixer



904L Static Mixer



CMX Static Mixer



PVC Static Mixer



CMH Static Mixer



PTFE Lined Static Mixer

# Major Projects



**Distillation For Privi Organics And Aarti Industries**



**Rallis , Dahej 2 Stage Distillation Turnkey Plant**



**Bhagyaraj Industries, Gorakhpur Multipurpose Distillation Plant**



**Taco Chemical , Turkey 100 TPD Ethyl Acetate Plant**



**Trsutin Tape (brofind Italy) , Dahej Solvent Recovery**



**GFL , Dahej 10 Column Solvent Distillation Plant**



**Bodal Chemicals Ltd.**



**Balaji Formalin Pvt Ltd**

# Critical Columns Supply Reference List

Sr. No.	Client	Location	Description	Sizes	MOC
1	Startpoint	Export	White Spirit Plant - 200 Ton/Day. Kerosene Distillation Plant	800 mm ID x 28 mtr Ht	SS316L
2	Bestech	Dubai	NMP Recovery Plant - 100 KLPD	1200 mm ID x 30 mtr Ht	SS304L
3	Bestech	Dubai	2000 TPM Pyrolysis Oil Fractionation Plant	1800 mm ID x 30 mtr Ht	SS316
4	GFL	Dahej	Vent Recovery Distillation Columns- 12 Nos	Ranging from 600 mm ID to 1000 mm ID with 44 mtr to 54 mtr Ht	SS304
5	Biocon	Banglore	SRS System	600 mm ID x 30 mtr Ht	SS304
6	GFL	Dahej	Columns + Packings : 10 Nos	Ranging from 600 mm ID to 1000 mm ID with 44 mtr to 54 mtr Ht	CS/SS316
7	GFL	Dahej	Columns , Kettles , Packing & Internals	800 mm ID x 24 mtr Ht	SS304

8	Rallis India Ltd	Dahej	6.5 KL Distillation System	800 mm ID x 20 mtr Ht , 800 mm ID x 24 mtr Ht	SS316
9	Balaji Amines	Hyderabad	EDA Columns - 6 nos	Ranging from 800 mm ID to 1500 mm ID with 40 mtr to 45 mtr Ht	SS304
10	TACO Kimya	Turkey	100 TPD Ethyl Acetate Plant	800 mm ID x 30 mtr Ht , 1200 mm ID x 36 mtr Ht	SS304
11	Aarti Industries	Tarapur	Column + Trays	1200 mm ID x 30 mtr Ht	SS304
12	Aarti Industries	Vapi	Columns	1100 mm ID x 54 mtr Ht	CS
13	Seya Industries Ltd.	Tarapur	Columns: 4Nos	Ranging from 600 mm ID to 800 mm ID with 24 mtr to 30 mtr Ht	SS316L
14	Balaji Amines	Hyderabad	EDA Columns - 6 nos	Ranging from 800 mm ID to 1500 mm ID with 40 mtr to 45 mtr Ht	SS304L
15	TACO Kimya	Turkey	100 TPD Ethyl Acetate Plant	800 mm ID x 30 mtr Ht , 1200 mm ID x 36 mtr Ht	SS304

16	Aarti Industries	JHAGADIA, GUJRAT	DISTILLATION COLUMN	550 mm ID x 3000 mm ht	SS317L
17	Bodal Chemical	DUDHWADA GUJRAT	DISTILLATION COLUMN Total 2 Nos	1300mm ID X 25 mtr ht	SA 516 Gr.70
18				800 mm ID X 36 mtr	SA 516 Gr.70
19	Matrix Life Science	Aurnagbad,	Liquid Separator	900 mm ID X 4 mtr ht	SS304
		Maharashtra	Distillation Column	1000 mm ID x 13 mtr ht	SS304
20	Swati Spentose	JHAGADIA, GUJRAT	SRP System	400 mm ID X,11 mtr ht	SS304
21	Rallis India	LODHA	Column (C-R13)BOTTOM DOME COLUMN	TAG-C-R13-COLUMN I.D $\phi$ 870 x 8 THK ,0.9 m Column	SS316
22	Emcure Pharmaceuticals	Kurkumbh	Column(TAG-C-1)	TAG-C-1-COLUMN I.D $\phi$ 500 x 6 THK , 2.53 m Column	SS316
23	Hikal Ltd		Distillation column with packing and internals	600 mm ID x 11 mtr ht	SS316



24	Swati Spentose	JHAGADIA, GUJRAT	Kettle with jacket & Agitator -3.5 KL Qty.1 no., Distillation Column Qty 1 Nos., Condenser Qty 1 Nos., Vent Condenser Qty 1 Nos. , Reflux drum : Qty.1 , Piping Scope: Inhouse fabrication & supply Liquid Separator	TAG-C-101-COLUMN I.D $\varnothing$ 400 x 5 THK ,10.61 m Column	SS316L
25	GFL	Dahej	Batch distillation Setup	150 NB ,20m Column	HASTELLOY C276
26	NACL	Srikakulam	Pilot Plant	50 NB 1 m Column	HASTELLOY C276
27	NACL	Srikakulam	Pilot Plant	80 NB 1 m Column	SS316



# HiTurb™ Heat Exchanger

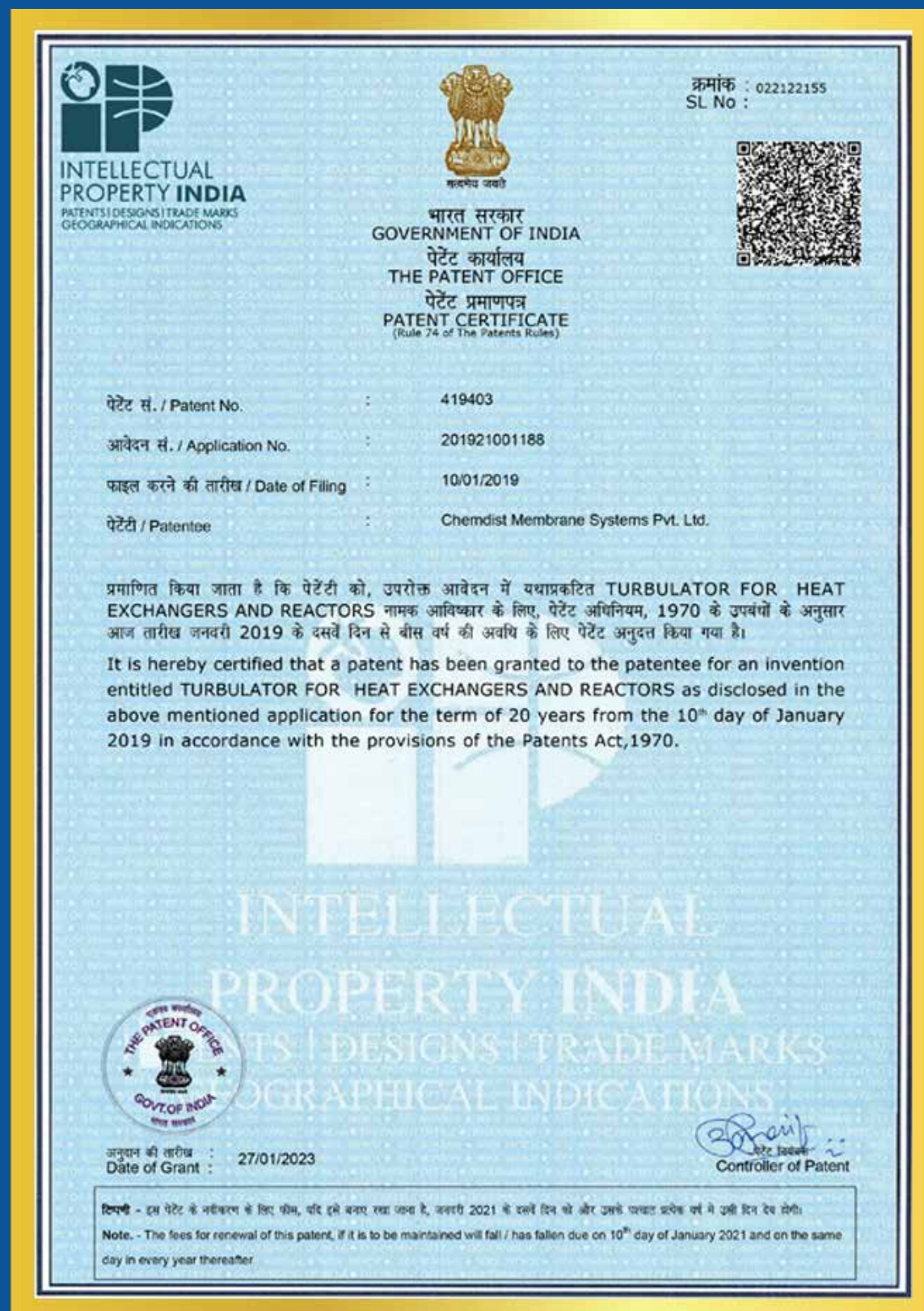

**Patent Granted**  
**Patent No. 419403**



- Simulation software for efficient and effective design of heat exchanger for various applications and operating conditions.
- Design of Heat Exchangers as per Latest ASME and TEMA standards.
- Different types of TEMA configurations like BEM, BEU, BKU, AEM, BEW, AEW, BES, AES, NEN etc.
- MOC – Carbon Steel, Austenitic Steel 300 Series, SS 904L, Hastelloy – C276, C-22, Duplex-2205, Halar Coated, Titanium.
- Chemdist has expertise in design of Overhead Condensers, Partial Condensers, Forced Circulation Reboilers, Falling Film Reboilers, Kettle Reboilers.

**30%-40% Increase in Heat Transfer Efficiency**

# Major Projects



# Critical Heat Exchanger Supply Reference List

Sr. No.	Client	Location	Description	MOC
1	Ascent India Tech. & Controls Ltd.	Malaysia	32 SQ. MT. & 83 SQ. MT.	SS316
2	Ajanta Pharma Ltd.	Pune	5.66 SQ. MT. & 10 SQ. MT	SS316 & MS
3	Schemt Co. Ltd.	Kuwait	2 SQ. MT. & 17 SQ. MT.	CS
4	Bestech FZE.	Dubai	100 SQ. MT. & 60 SQ. MT.	SS316 & MS
5	Gujarat Fluorochemicals Ltd.	Dahej	11 SQ. MT.	SS304
6	Hitachi Plant Technologies India. Pvt. Ltd.	Dahej	45 SQ. MT.	SS304
7	Oblivon	Kenya	5 SQ. MT.	SS316
8	P20 Green Refineries Ltd.	Devas	5 SQ. MT.	SS316

9	Aarti Industries Ltd.	Tarapur, Silvassa Pitampura, Vapi	300 SQ. MT & 250 SQ. MT.	SS304/CS
10	Acebright India Pharma Ltd.	Bangalore	2 SQ. MT.	SS304
11	Anthem Biosciences Ltd.	Bangalore	10 SQ. MT.	SS304
12	Fibre Factory	Saudi Arabia	80 SQ. MT.	MS
13	Eternis Fine Chemicals Ltd.	Kurukumbh	2 SQ. MT. & 16.2 SQ. MT.	SS304
14	Symbiotica Speciality Ingredients Sdn. Bhd.	Malaysia	5 SQ. MT. & 10 SQ. MT.	SS316
15	Chinai Agencies Pvt. Ltd.	Tarapur	2 SQ. MT. & 5 SQ. MT.	SS304
16	Biocon Ltd.	Bangalore	30 SQ. MT. 20 SQ. MT. & 6 SQ. MT.	SS316

# Agitators & Reactors

---

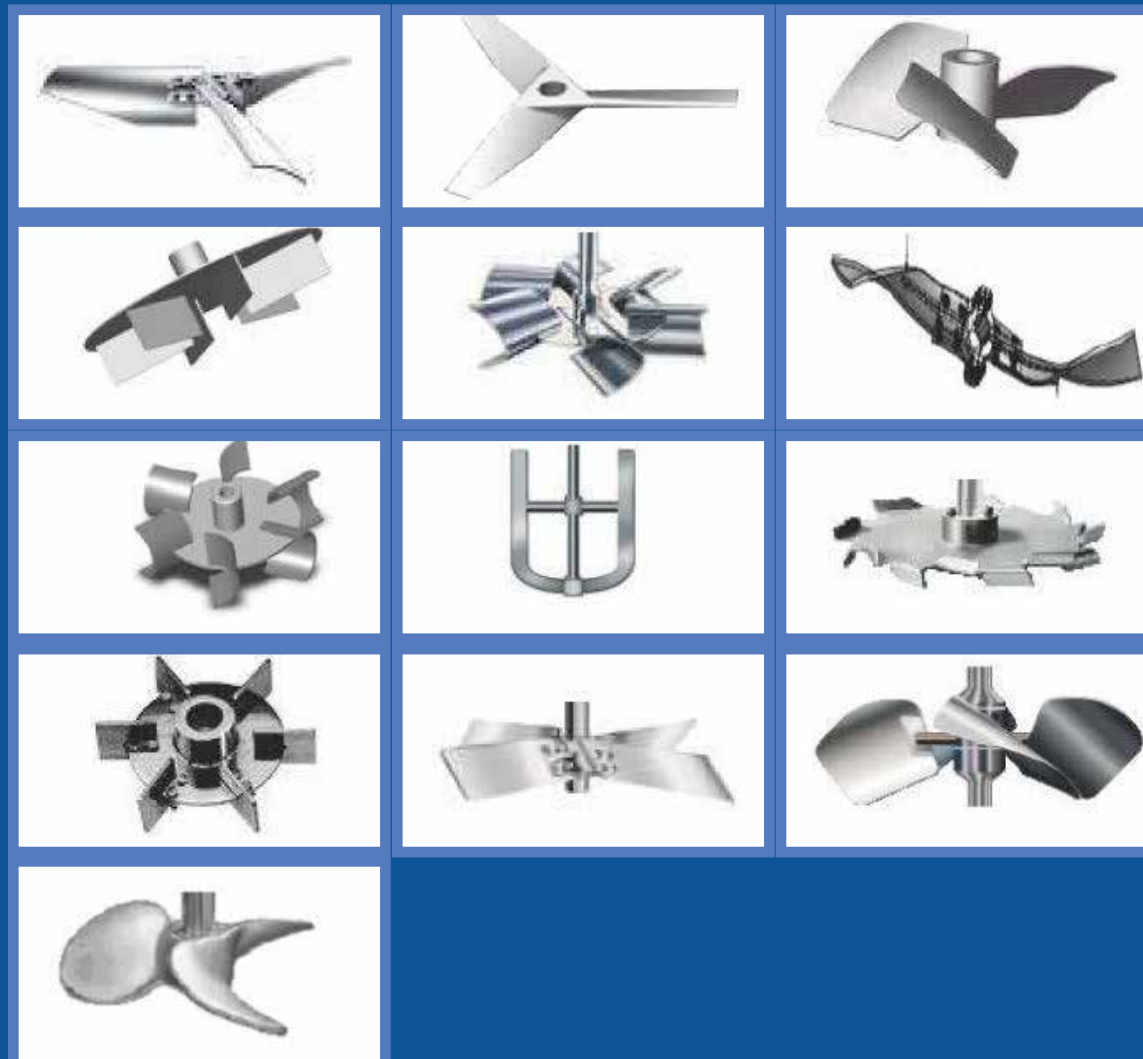

## Agitated Reactors

---

- Precisely designed for range of operating conditions.
- Capacity Range – Upto 42 KL
- Maximum Pressure Handle d- 100 bar
- MOC – Carbon Steel, Austenitic Steel 300 Series, SS 904L, Hastelloy – C276, C-22, Duplex-2205, Halar Coated, Titanium
- Internal Coils, External Limpets, Jacket for heating and cooling arrangements

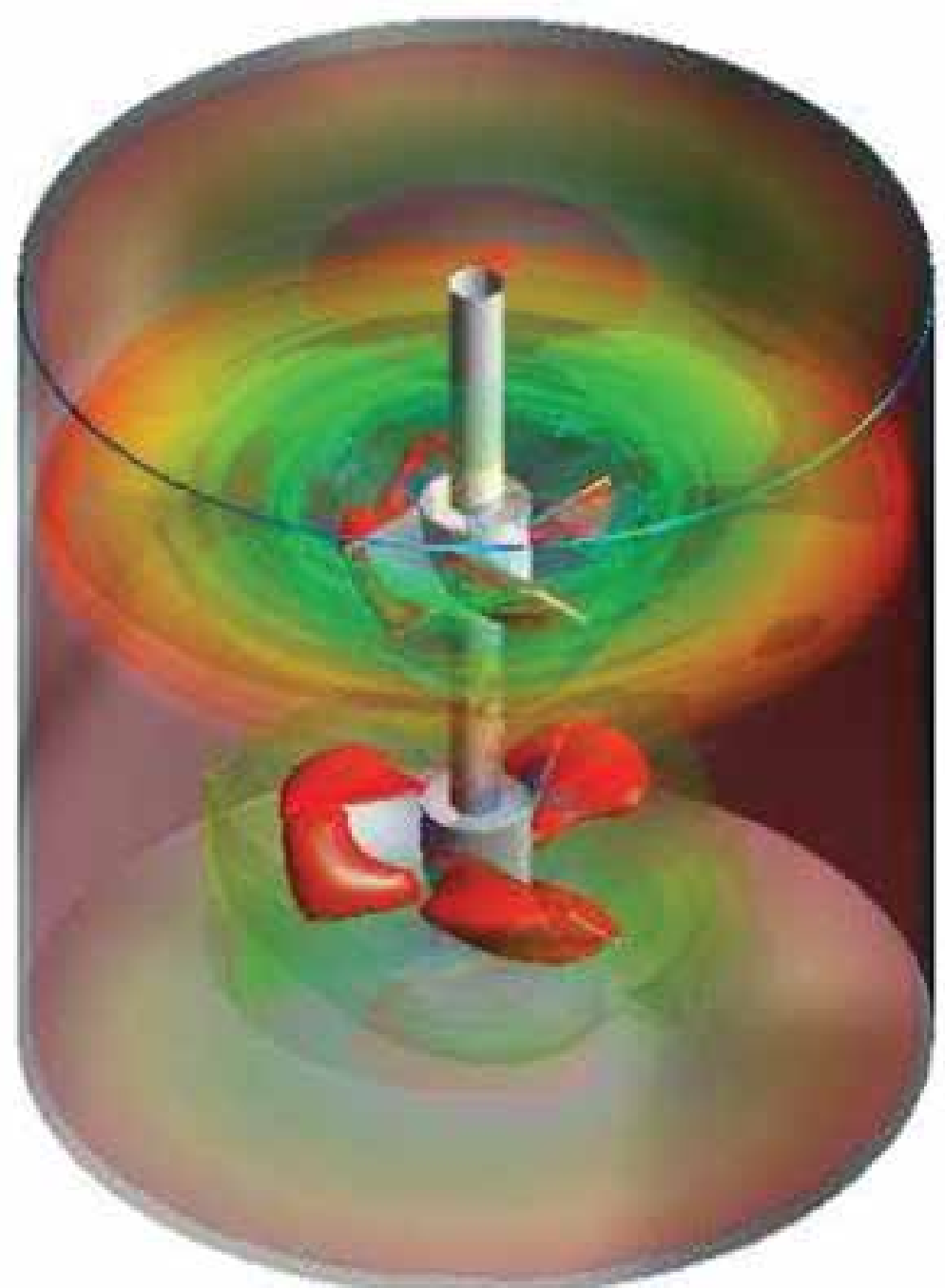

**Our Expertise- Hydrofoil Impellers**

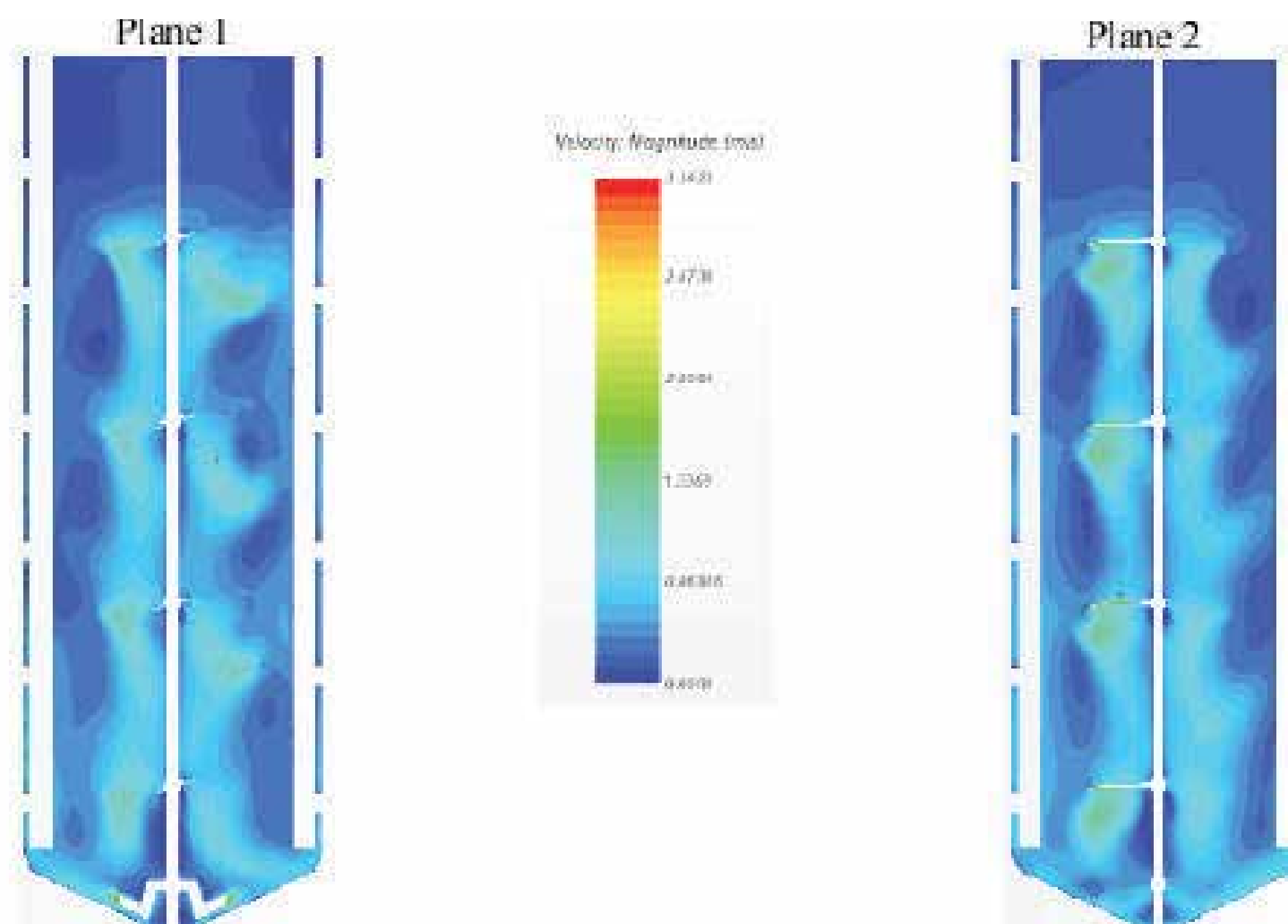

**Computational Fluid Dynamics CFD**

# CD Smart Mixer

CD Smart Mixer comes with advanced sensing techniques as well as AI and ML, which will reduce the manual dependencies, conserve the energy. This will directly contribute in reduction of operational cost and increase in the profit margin.

Conventional Mixer	CD Smart Mixer
Manually Operated	No manual intervention required
No feedback from Reactor	It always gives you feedback
Cannot take the decision on its own	Using AI and ML, reactor can take the decision on its own
Cannot communicate with other equipment	Using the Open source software, it can communicate with other equipment
Local Operation and monitoring	Remotely operated or monitored from anywhere





# What are the advantages of CD Smart Mixer?

---

- Absolute '0' Manual intervention
- Energy efficient due to its excellent feedback mechanism
- Improved product quality due to smart sensors
- No wastage of production cycles
- More yield per cycle due to reduction in time per cycle
- Prejudgment of mixer failure or damage due to smart sensors
- '0' Safety concerns
- Remotely operated or monitored



# Major Projects



**Biocon Malaysia**



**3 KL Reactor / 5 KL Day Tanks**



**40 KL Reactor**



**5 KL Reactor**



**20 KL Reactor**



**40 KL Reactor**

# Reactor Domestic/Export Client List

Sr. No.	Client	Location	Capacity	Scope	MOC
1	Laxmi Organic Industries	Mahad	20 KL (2 Nos.)& 15 KL (2 Nos.)	Gas Induction (Ethoxylation Reaction) with 3 and 2 internal Coils.	SS316
2	GFL	Gujarat	40 KL (3 Nos.)	Monomer Mixing tank with limpet coil & internal draft tube.	SS304
3	GFL	Gujarat	42 KL (2 nos.)	Neutralization Reactors with external Limpet Coil	SS304
4	GFL	Gujarat	18 KL & 9 KL	Filter feed Reactor & Extraction Reactor with Halar coating	CS with Halar Coating
5	GFL	Gujarat	18 KL (2 nos.)	Halex Reaction Reactor with double limpet coil.	SS316
6	GFL	Gujarat	12 KL	Nitration Reactor with internal & External coil	SS304L

7	Rallis India Pvt. Ltd.	Gujarat	8KL & 9 KL	Product recovery system (Turn Key)	SS316
8	GFL	Gujarat	9KL,10KL, 1KL, 500 LTR,	Surfactant recovery system (Turn Key)Equipment supplied.	SS316
9	Grasim	Gujarat	20KL	Zink Recovery System.	SS316
10	Neogen Chemicals	Gujarat	1KL,3KL,5KL	Supply of High Pressure & Hastelloy Reactors.	Hastalloy
11	C1 Water	Dubai	20 KL & 10 KL	Blending System	SS316L
12	HK Wentworth	Bangalore	1 KL	Supply of Reactor	SS316L
13	Matrix Fine Science	MH	10KL,5KL	Supply of Reactor	SS316L
14	Graviton	MH	1 KL	Distillation System.	SS316L
15	Farabi Yanbu	Export	35KL (02 Nos.), 25KL (02 Nos.), 6KL,10 KL	Blenders System	SS316L

# High Pressure Reactor Client list

16	GFL	Dahej	250 Ltr	Batch distillation Setup	HASTELLOY C276
17	NACL	Srikakulam	20 Lit High Pressure Reactor	Pilot Plant	HASTELLOY C276
18	NACL	Srikakulam	10 Lit High Pressure Reactor	Pilot Plant	SS316
19	NACL	Srikakulam	30 Lit High Pressure Reactor	Pilot Plant	SS316
20	NACL	Srikakulam	50 Lit Reactor	Pilot Plant	SS316

# Tanks & Vessels

---



# Tanks & Vessels

---

A pressure vessel is a storage vessel or tank designed to hold fluids (gases/liquids/both) at high pressures. Material of Construction (MOC) Offered: - CS (IS 2062 Gr A/B, SA 516 Gr 60/70), SS 316, SS 304, SS 316 L, SS 304 L. SS 904, MS IS2062, hastalloy etc.



# Critical Tanks & Vessels Supply Reference List

Sr. No.	Client	Region		Description	MOC
1	Air Science	Odisha	East	170 KL Storage Tank	CS
2	SNF SAS	GANDHIDHAM	West	200 KL TANK	SS316L
3	GFL	RANJITNAGAR	West	Settlers & Vessels	SS304
4	BALAJI AMINES	HYDERABAD	South	Pilot Reactor With Agitator	SS304
5	Rand Poly Products Pvt. Ltd.	PUNE	MH	10 KI Tank, Ribbon Blender & Screw Melter	SS316
6	Rand Poly Products Pvt. Ltd.	PUNE	MH	40 KI Solvent Tank, 6.2 KI Reactor	SS304
7	Heni Drugs Pvt. Ltd.	SAIRGRAM	West	SS Vessels	SS316
8	Rand Poly Products Pvt. Ltd.	Devas	MH	13 KL Vessel	SS304

9	Deepak Fertilizer	Taloja	MH	8 KL Batch Tank	SS304
10	Snf India Pvt. Ltd.	Vizag	South	1 KL Hsd Buffer Tank	CS
11	Bhagyaraj Impex	Delhi	North	15 KL Multipurpose Srp	SS316
12	GFL	Dahej	West	C-1489 Project Tanks & Vessel	CS
13	Anthem Biosciences Pvt. Ltd.	Banglore	South	Columns & Tanks	SS316
14	GFL	Dahej	West	Vessels	CS
15	Rand Poly Products Pvt. Ltd.	Pune	MH	8 KL Tanks X 2 Nos	SS304
16	Clean Science	Pune	MH	6 KL Reactors X 2 Nos , 3 KL Crystalliser X 2 Nos	SS316





# Food & Pharma Equipments

---



**Emcure Pharma**

# Evaporation Technology

---



- Multiple Effect Evaporator (MEE)
- Agitated Thin Film Evaporator (ATFE)
- Agitated Thin Film Dryer (ATFD)
- Wiped Film Evaporator (WFE)
- Zero Liquid Discharge Plant (ZLD)
- Falling Film Evaporator
- Forced Circulation Evaporator
- Mechanical Vapour Re-compression Evaporator (MVR)

# Major Projects



**Jivo Wellness  
ATFD Plant**



**Hikal Limited  
Zero Liquid discharge System**

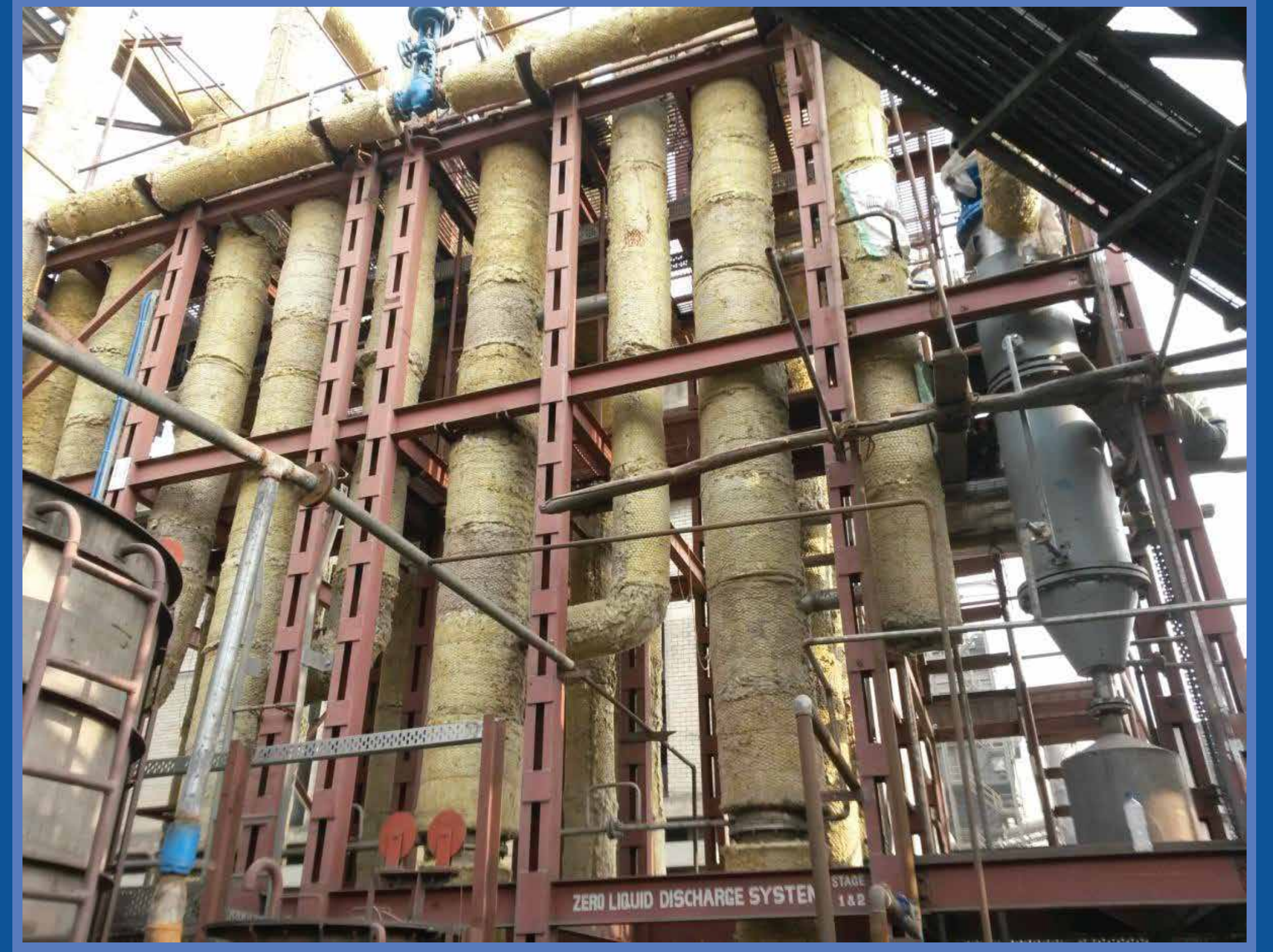

**ATFD For Zero Liquid Discharge Plant  
Grasim Aditya Birla Group, Satana**

# Major TurnKey Projects Domestic

Sr. No.	Client Name	Systems
1	Chemtel	Ethanol+ Water Distillation System
2	Asian Paints	Solvent (Xylene) Recovery Skid
3	Granules India	100KLD DAA Acid Turn Key
4	Rallis India	Distillation Turn key
5	SJS Biotech	Distillation Turn key
6	Biocon	Distillation Turn key
7	Brofind	Solvent Recovery System
8	Pashupati Poly	Distillation
9	Bhagyaraj Impex	15 KL Multipurpose SRP
10	Om Sai Corporation	Distillation
11	Aarti Industries Lt	RDC Type Liquid - Liquid Extraction
12	Singh Plasticiser	LLE/ Distillation
13	Sajjan India Ltd	Octanol Distillation System

14	Pashupati Polytex	Distillation System
15	Meghmani Industries	Distillation System for HNO <sub>3</sub> , H <sub>2</sub> O & H <sub>2</sub> SO <sub>4</sub>
16	Green Joules	Straight path distillation Plant
17	Graviton Life care	Distillation Turn key
18	Eternis Fine Chemicals	Distillation Turn key
19	Laxmi Organics	Distillation Setup
20	P20 Refinery	Used Oil Plant
21	Cardolite	Ethyl Diamine Scrubbing System
22	Grasim	Zn Recovery Plant
23	IPCA Laboratories	Solvent Recovery Plant
24	GFL	Scrubbing Systems



# Deep Bed Scrubber System GFL, Dahej Process Licensor : Dupont

---



## Granules India

---

- 100KLD dilute acetic acid purification
- BEP and DEP with supply of equipments, structure piping etc



# Rallis, Dahej

---

2 Stage Distillation Turnkey Plant



# Biocon, Bangalore

---

- Installation of critical 3 floor structure on critical location.
- Successful commissioning done.
- Desired purity and product rate achieved.
- Instrumentation with automation support.



# GFL, Dahej Solvent Distillation Plant : Total 10 Columns

---

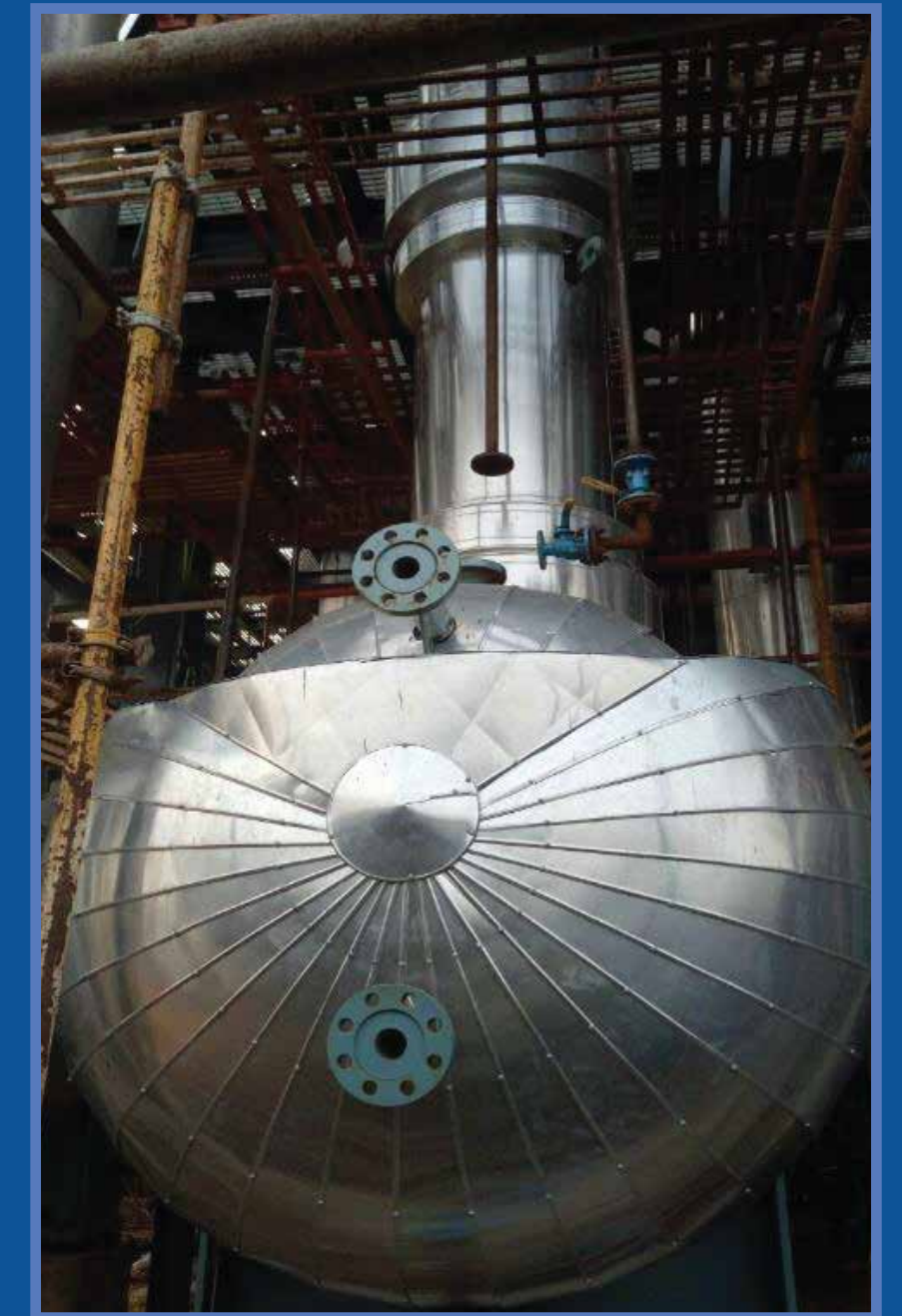
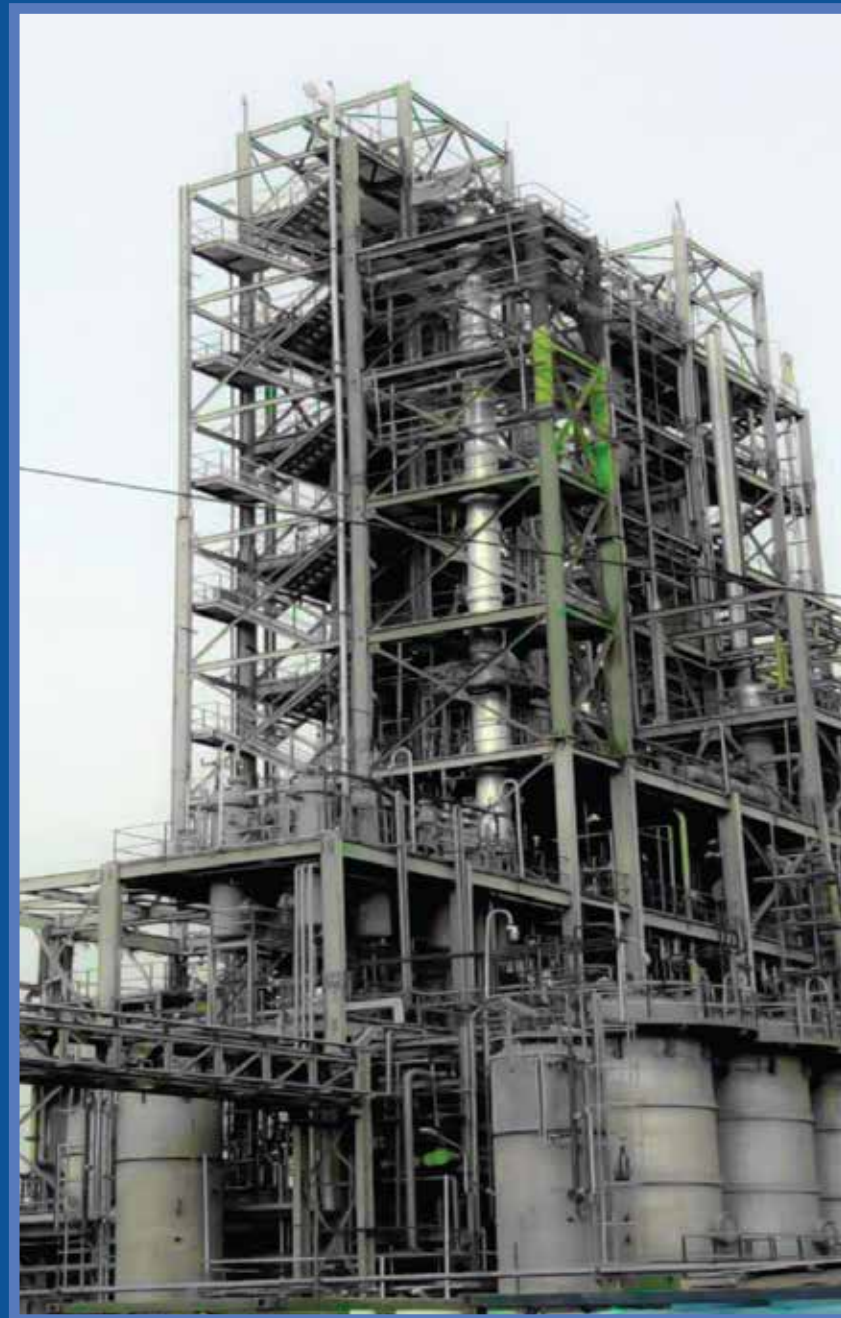

# Trustin Tape (Brofind Italy) , Dahej Solvent Recovery

---





# Bhagyaraj Industries, Gorakhpur Multipurpose Distillation Plant

---



# HPCL, Vizag India

---

4 KL - 2G Ethanol Plant



# Distillation For Privi Organics And Aarti Industries

---



# Brofind, Dahej

---



# Bodal Chemicals Ltd. Sykha GIDC, Bharuch

---

- MCB Moisture Removal Column
- PNCB-ONCB Superfractionation Column
- ONCB Polishing Column

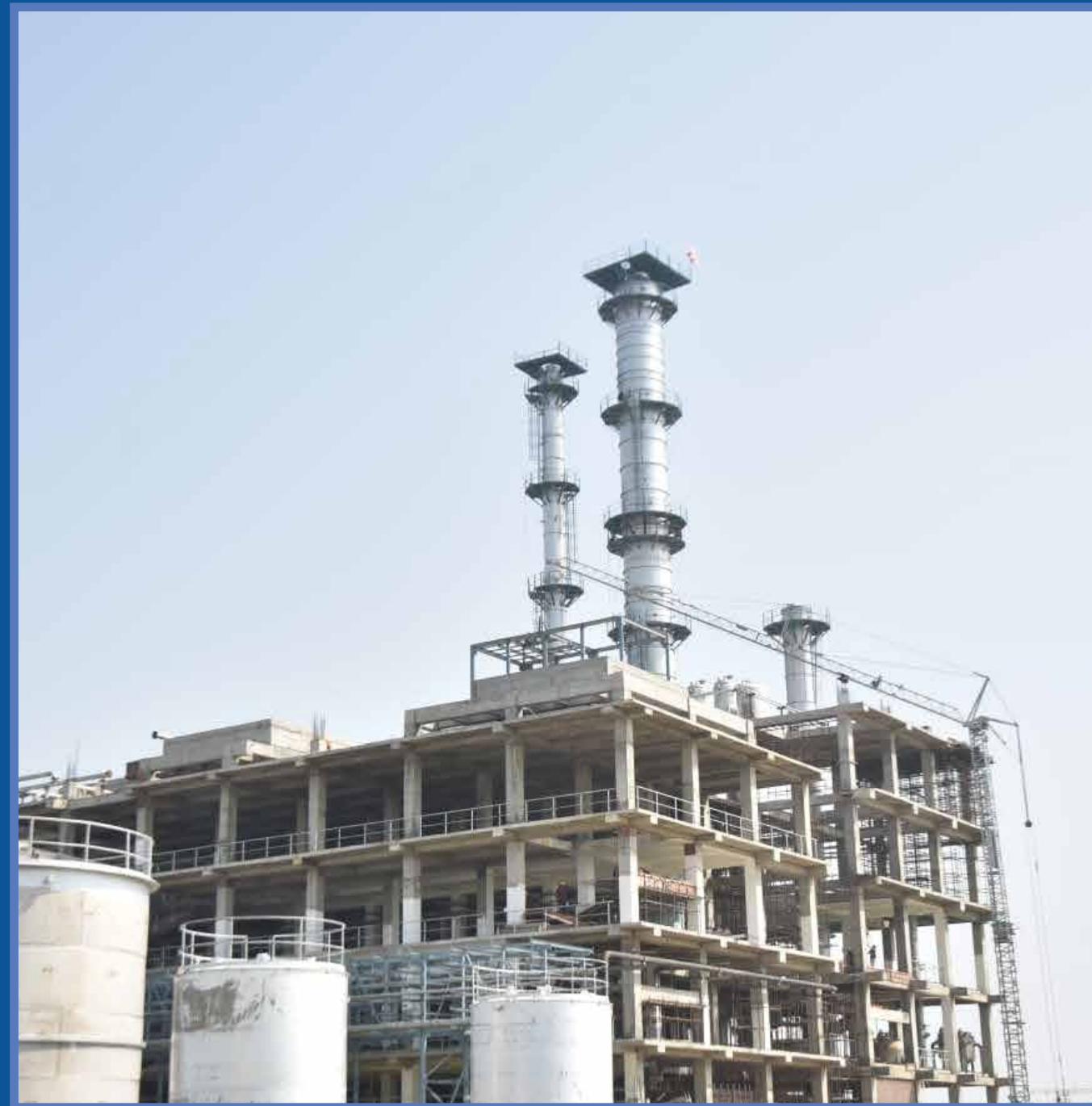

# Cadila Pharmaceuticals, Dahej

---

- 150 KLPD Methanol, Acetone, Mesityl Oxide Solvent System



# Gulbrandsen Industries LLP. Dahej

- 50KLPD Methanol Recovery System

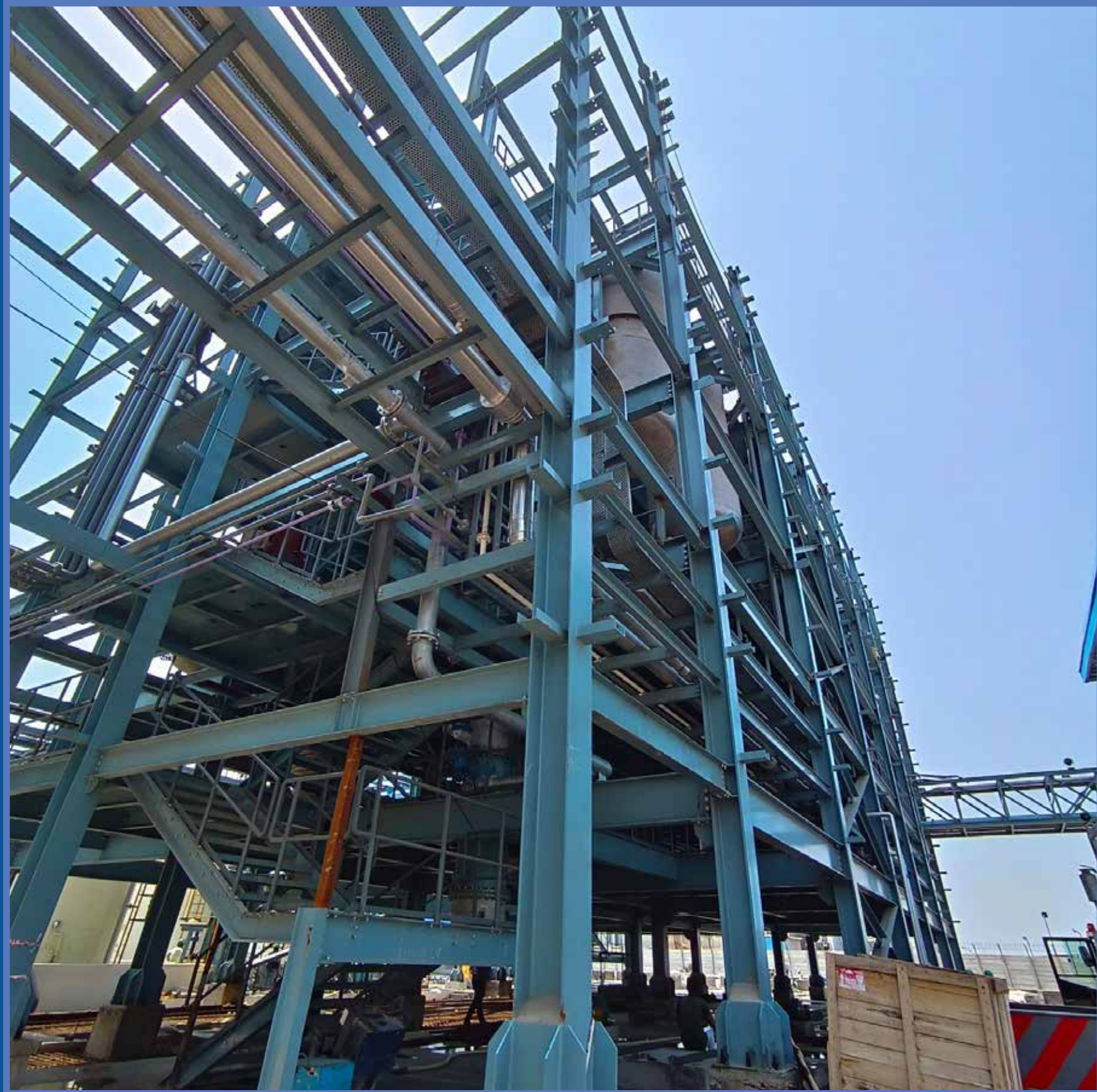

# Chemdist Ethyl Acetate & Acetic Acid Technology

---



**AA-72 TPD Jubilant Lifesciences**



**AA-80 TPD Jubilant Lifesciences**



**EA-72 TPD Jubilant Lifesciences**

# Rallis India

---

- Erection was done within 20 days
- 20 Batches were taken within 60 days
- Simulation results achieved at actual in plant
- We got Certificate of completion



# Aarti Industries Ltd.

---

- First time supply of RDC column
- RDC column running properly with desired output.
- PLC based control provided.

# Brofind, Dahej

---

- Installation was done within specified time
- Critical ducting and Piping was done successfully
- Successful commissioning done.
- We had work with Italian Based Company.



# Skid Mounted Pilot Lube Blending Plant For Castrol British Petroleum

---



## Farabi Yanbu Petrochemical, Saudi Arabia Blending System

# Major Turn-Key Projects Overseas

---

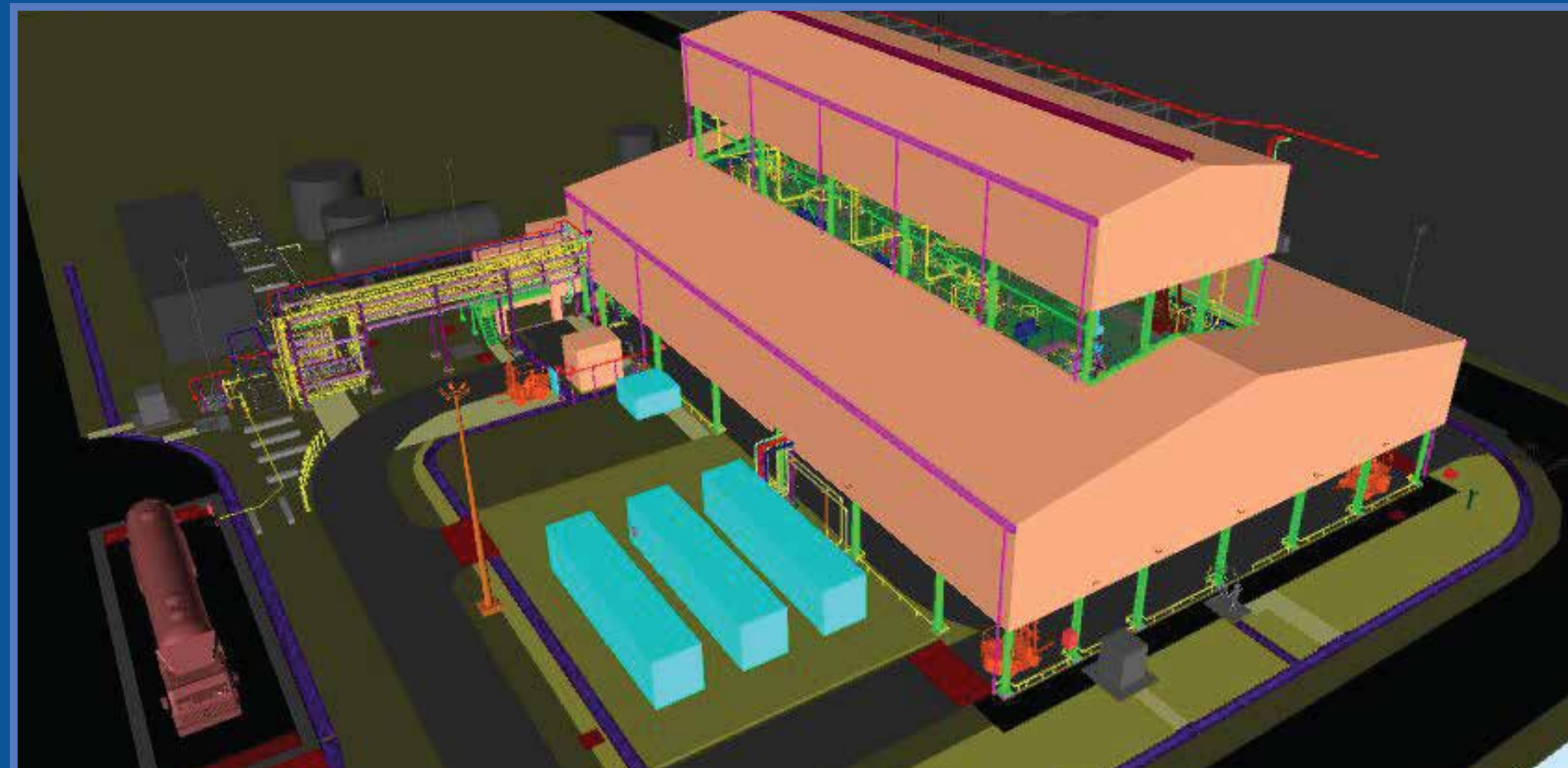

## Farabi, Polo

---

- Process oil & Lube Oils Blending Plant 140 KMTA brown field project.
- BEP was completed by Elixir Engineers, Netherland
- CDPS scope is detail engineering & modular skid supply.
- Preparation of construction tender for site execution.
- Project Management & site supervision



# Major Turn-Key Projects Overseas

---

## 24000 Lit/day Kerosene Fractionation Plant Kuwait



6 Nos's Skid Mounted  
Pilot Plants For Pan Oil Dubai

Distillation Plant,  
USA

200 TPD Fractionation  
Plant, Dubai

Anisole Plant,  
Saudi Arabia

# GREEN Energy Chemicals, Turkey

---

- 50KLD Corn Syrup Based Distillery
- BEP and DEP with supply of equipments



# Taco Chemical, Turkey 100 TPD Ethyl Acetate Plant

---



# Oil Distillation, Saudi Oil Company

---



## Multipurpose Reaction Facility Global Chemical Industries ( ADDAR Group), KSA

---



# Oil & GAS PROCESS TECHNOLOGY

## N-Paraffin Separation

- Adsorption Based Processes
- Urea Adduct Process

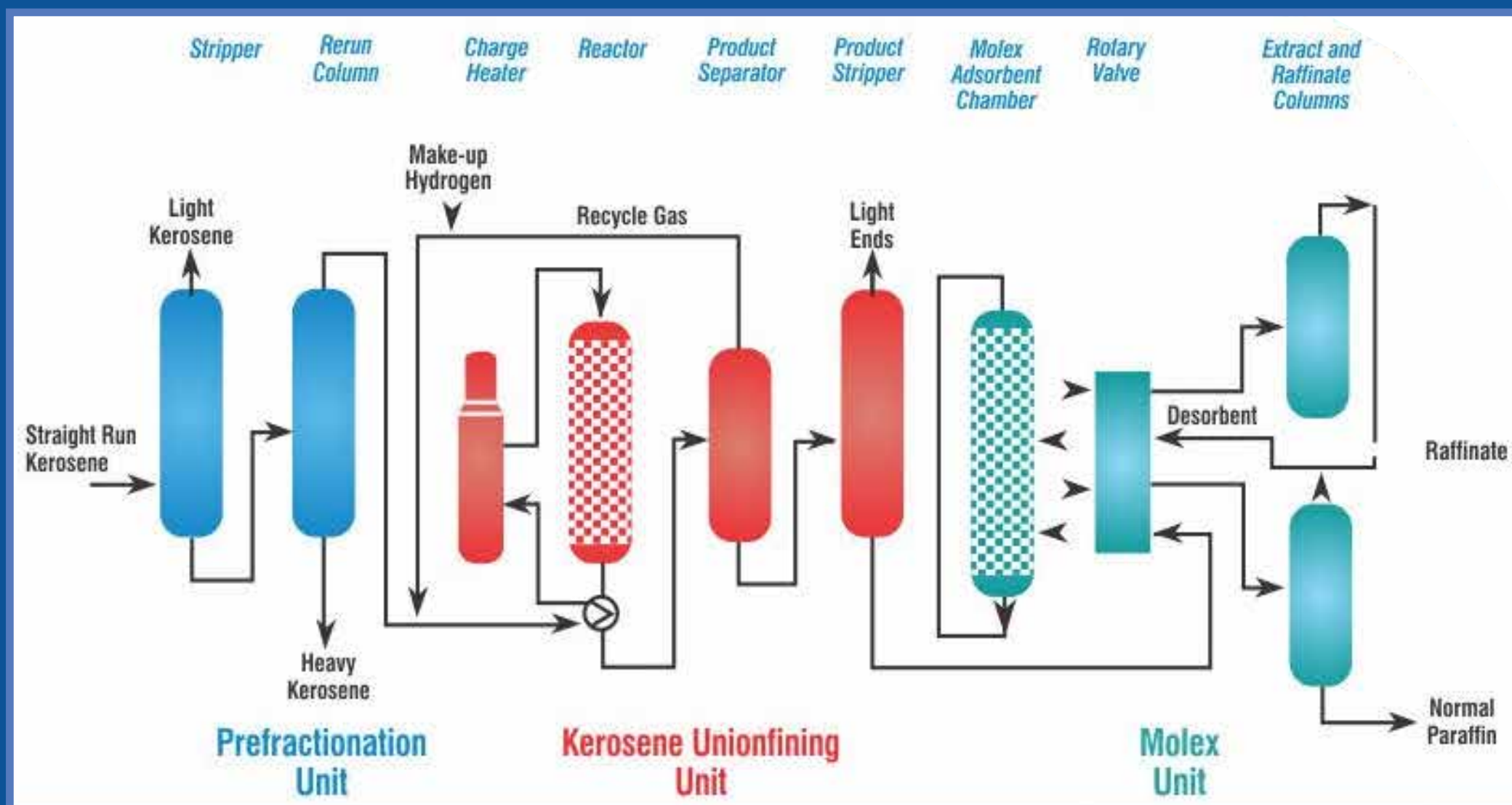

## Used Oil/lube Oil Refining

- Use to restore the characteristics of used Oil

## Pyrolysis Oil Fraction

- To Produce Light Fuel Oil & Less Residual Char

## Transformer Oil Reclamation

- Recycling of Waste Transformer Oil

## Glycol Dehydration

## Blending Units

## Propane & Butane Distiller

## Condensate Fractionation Plant

- Condensate are separated according to the boiling point
- Applicable for LPG, Naphtha & Kerosene

## White Spirit & Mineral Production

- Condensate are separated according to the boiling point
- Applicable for LPG, Naphtha & Kerosene

# Biggest Jobs Executed



Aarti Industries Ltd (Distillation Column)



Balaji Amines



SNF –Tank



Laxmi Organic Industries (Reactor)



Privi Organics

**Distillation Column: Dia 4.2 m and 67 m Height**

**Reactor : 42 KL**

**Tank : 200 KL**

**Pressure : 100 bar.**

# In-House Pilot Plant Facilities

- Distillation Set-Up- 5 L
- Thin Film Evaporator Set-Up
- Membrane Distillation - 10L and 1 KLD
- Pervaporation - 10L and 1 KLD
- Ultrafiltration and Nano Filtration - 10L and 1 KLD
- Agitated Thin Film Dryer – 1.5 sq m
- Wiped Film Evaporator – 1.5 sq m
- Batch Distillation – 10 L and 100 L
- Fermentor – 100 L



# Engineering Capabilities

Chemdist Provide engineering services, procurement services of equipment, materials and services, construction management as well as commissioning support for the plant.

- Feasibility Study
- Detail Engineering
- Instrumentation
- Electrical
- Mechanical
- Basic Engineering Package (BEP)/  
Front End Engineering & Design (FEED)
- Piping
- Civil, Structural & Architectural Design
- Health Safety & Environment
- Quality Control
- Procurement Management
- Construction Management

**We follow these Standard : ASME, API, DIN, TEMA, GEP, GMP.**



# 3D Modeling

---

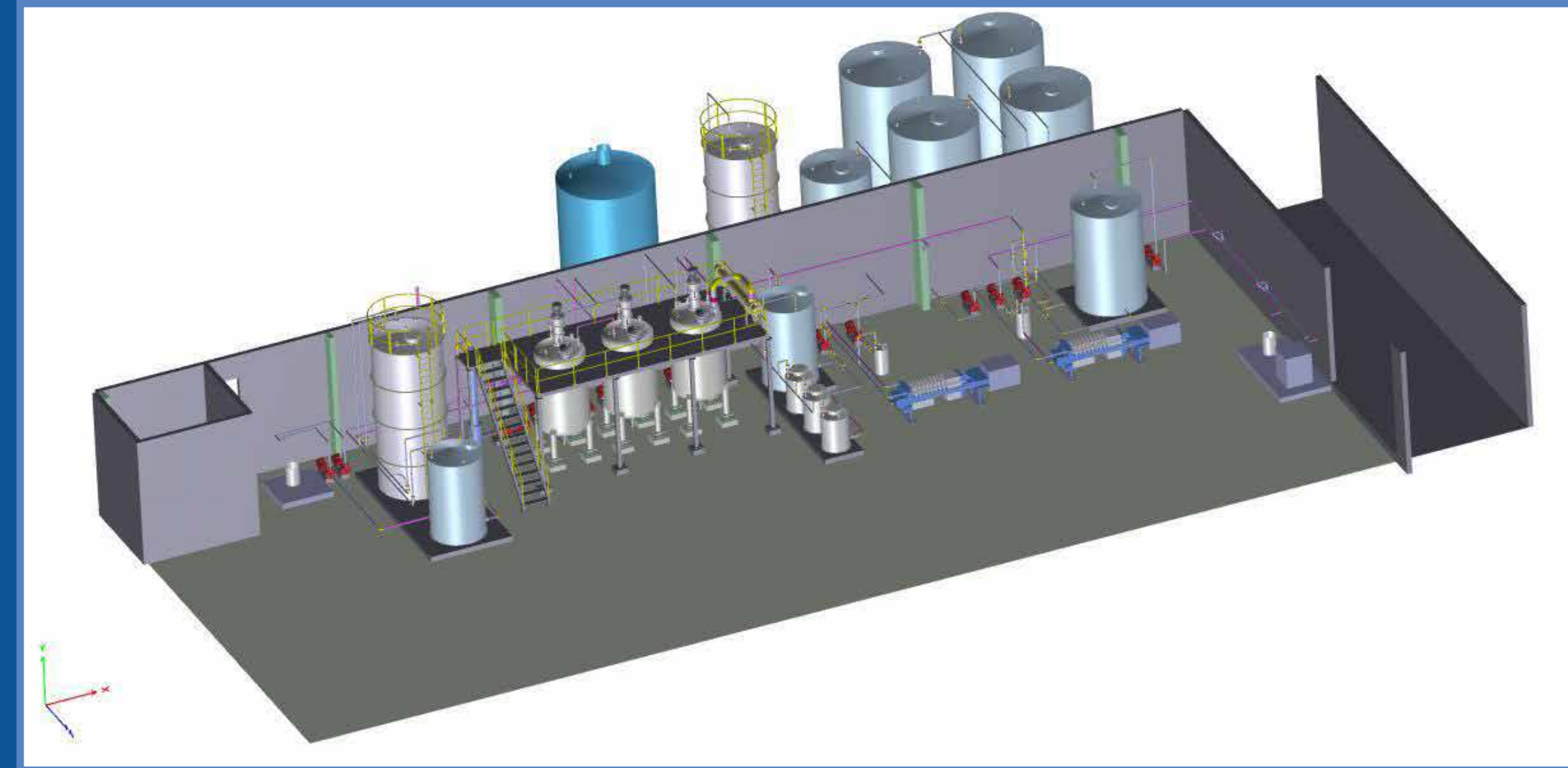
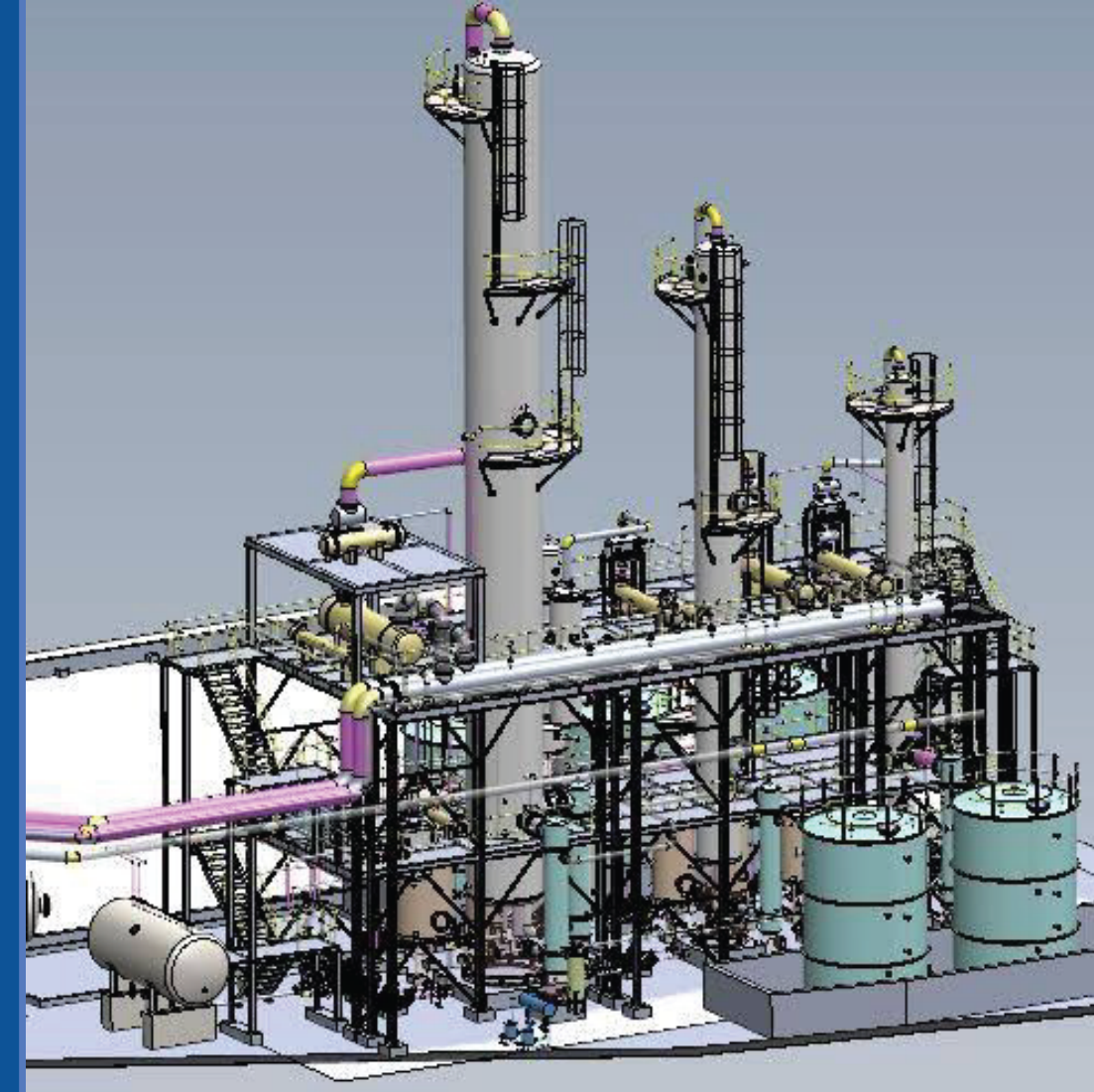
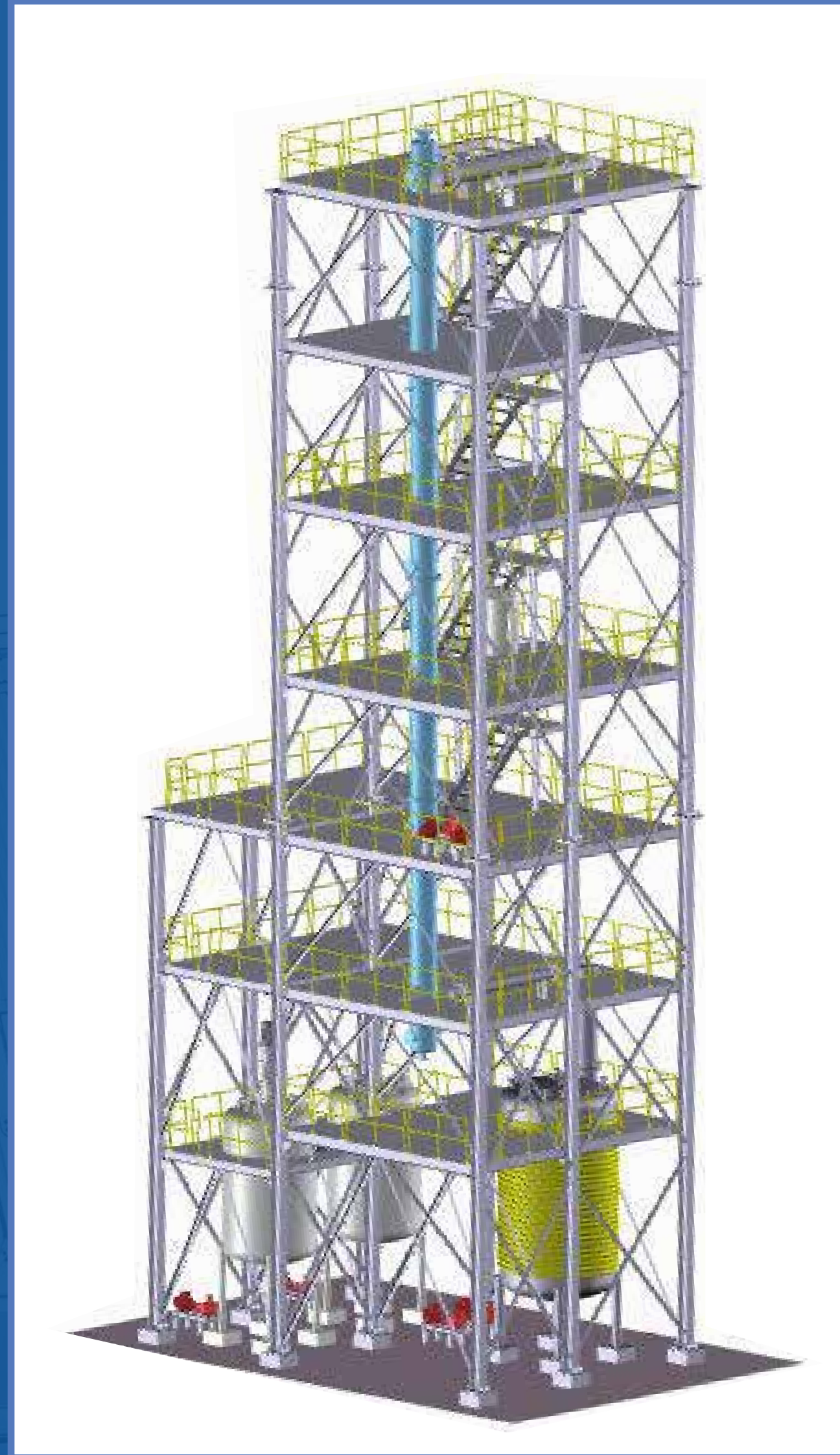



# Process Simulation and Process Design Software

Sr. No.	PROCESS	MECHANICAL
1	Mixer Settler	PV-Lite
2	ASPEN	CADEM
3	PRO II	Solid Works
4	HTRI	Navisworks

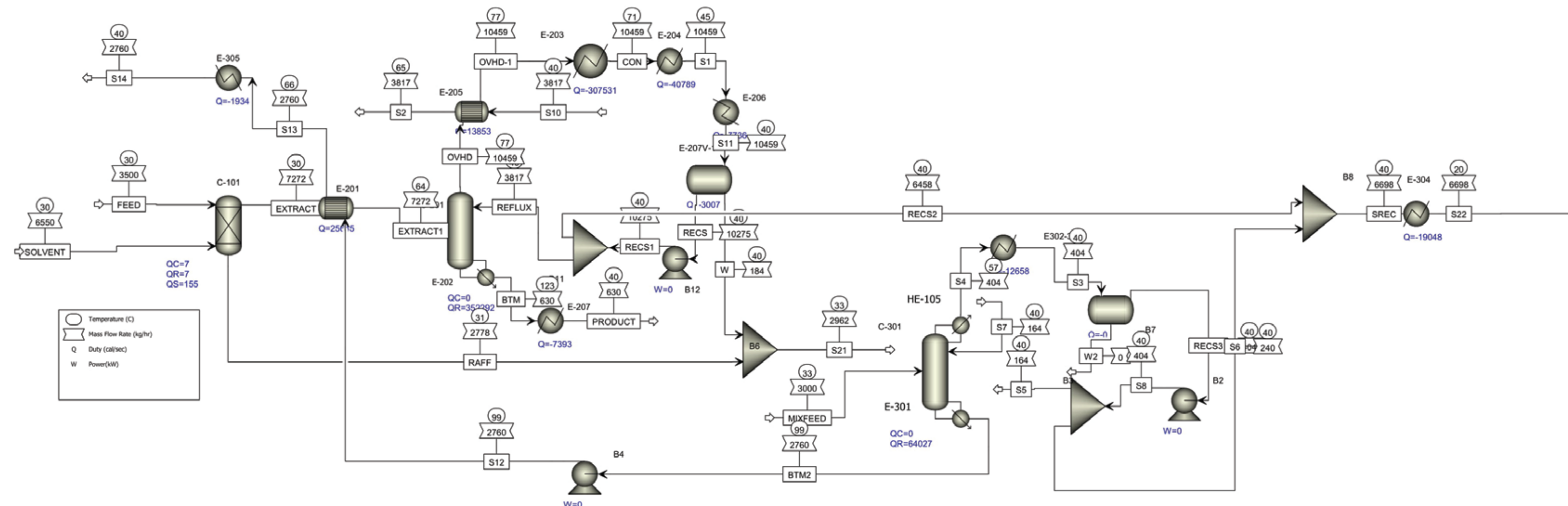

# Certifications

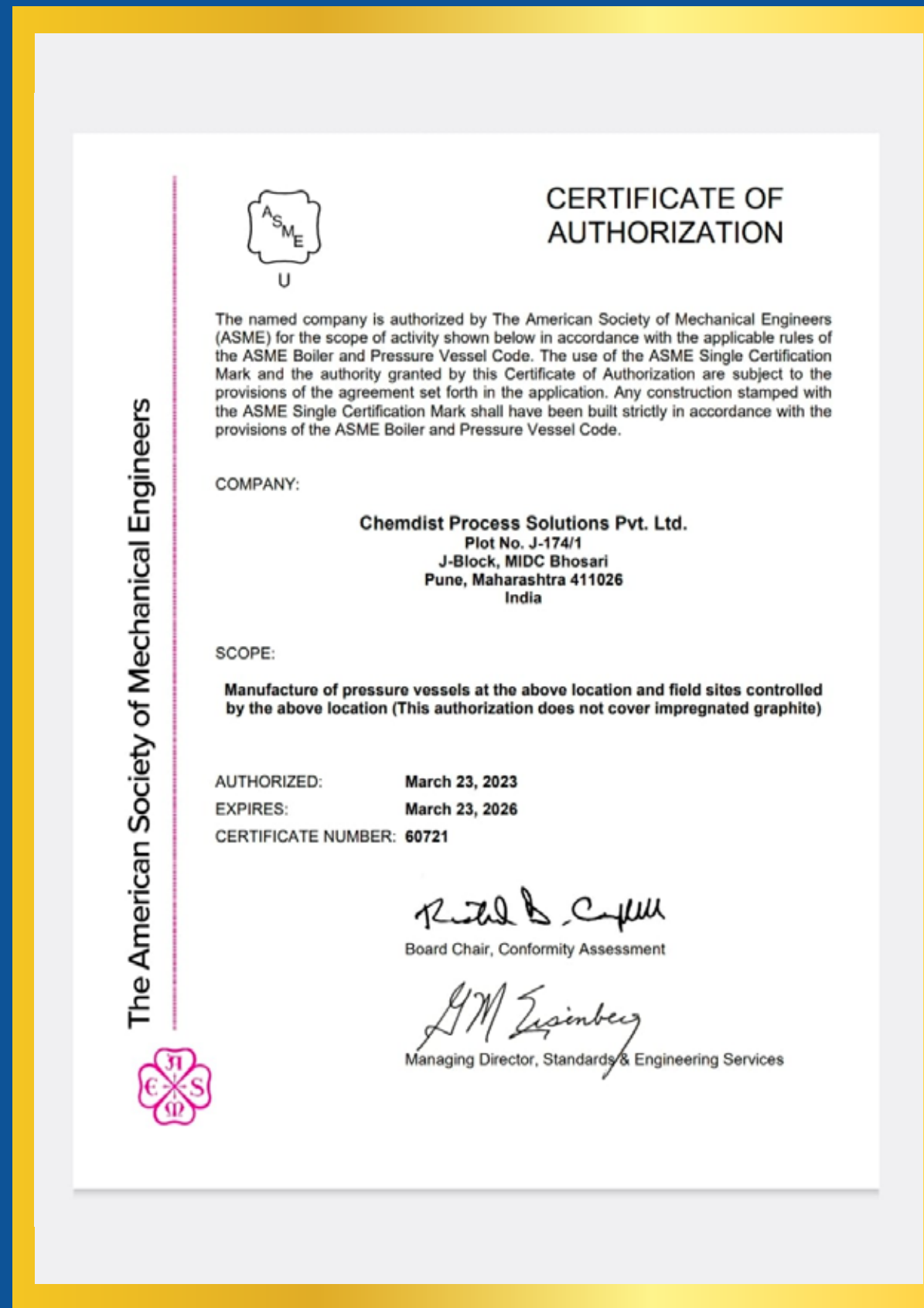

ASME U STAMP



ISO 9001:2015

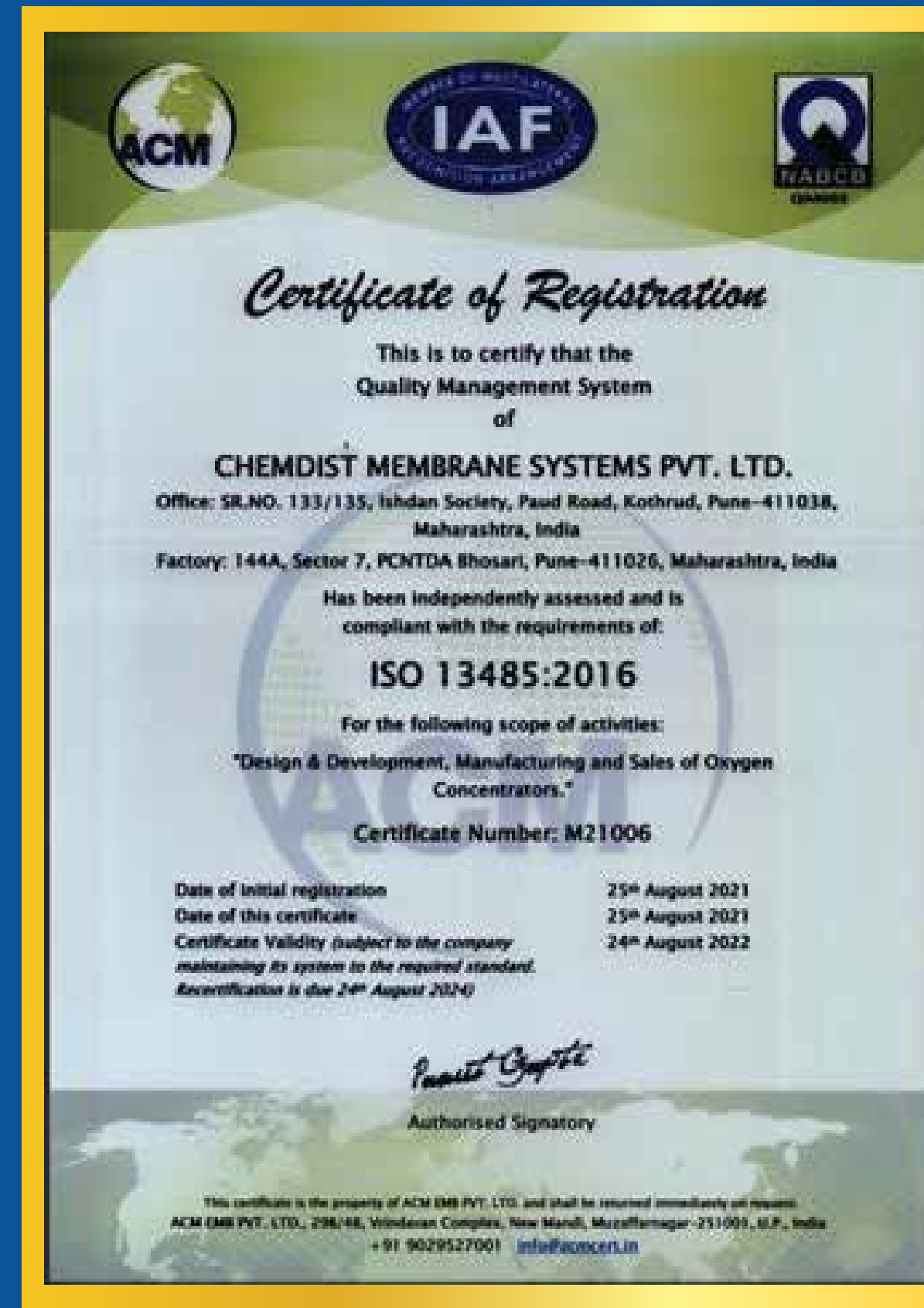

ISO 13485:2016

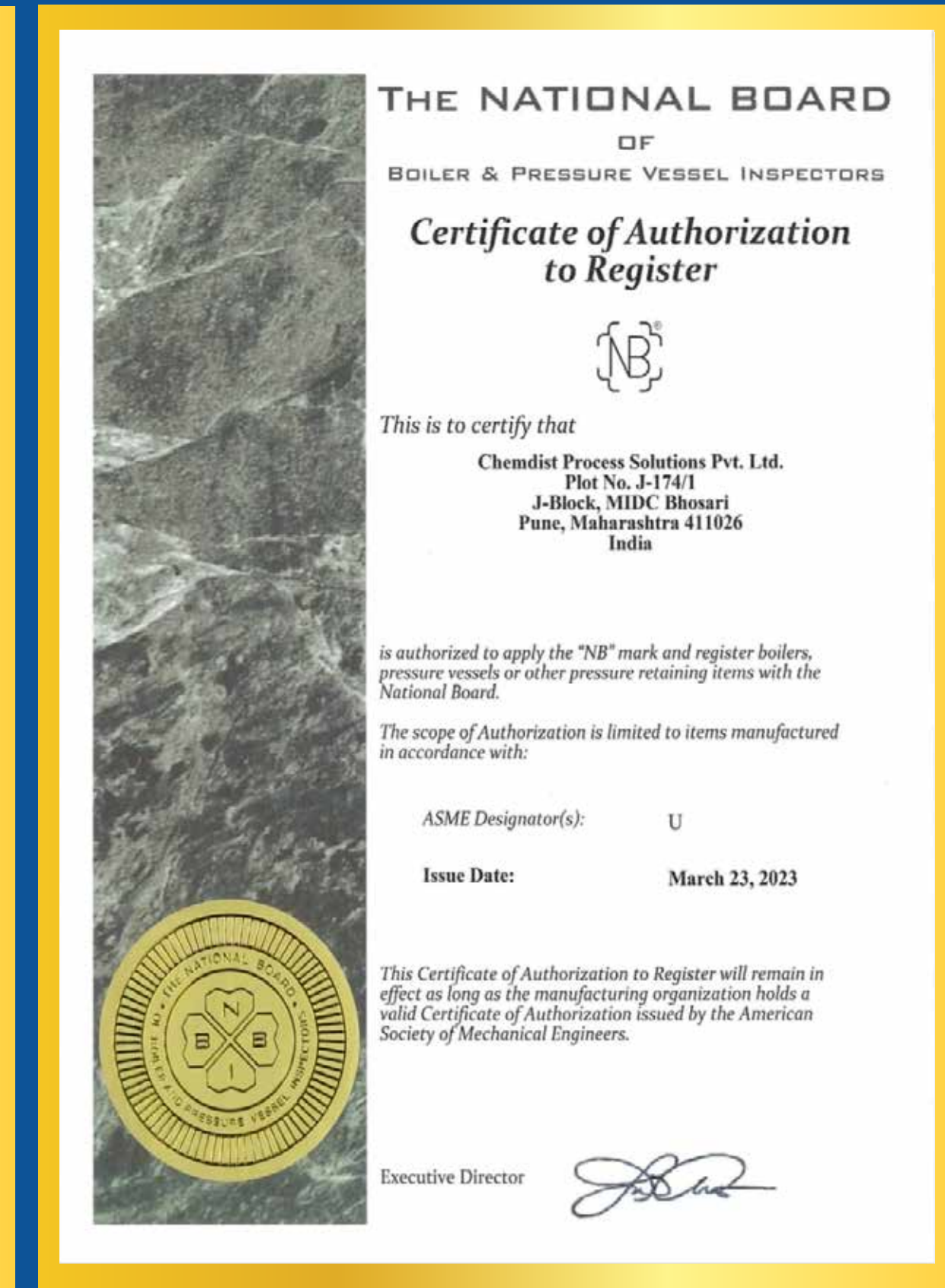

NB STAMP

# Membrane Technology

---

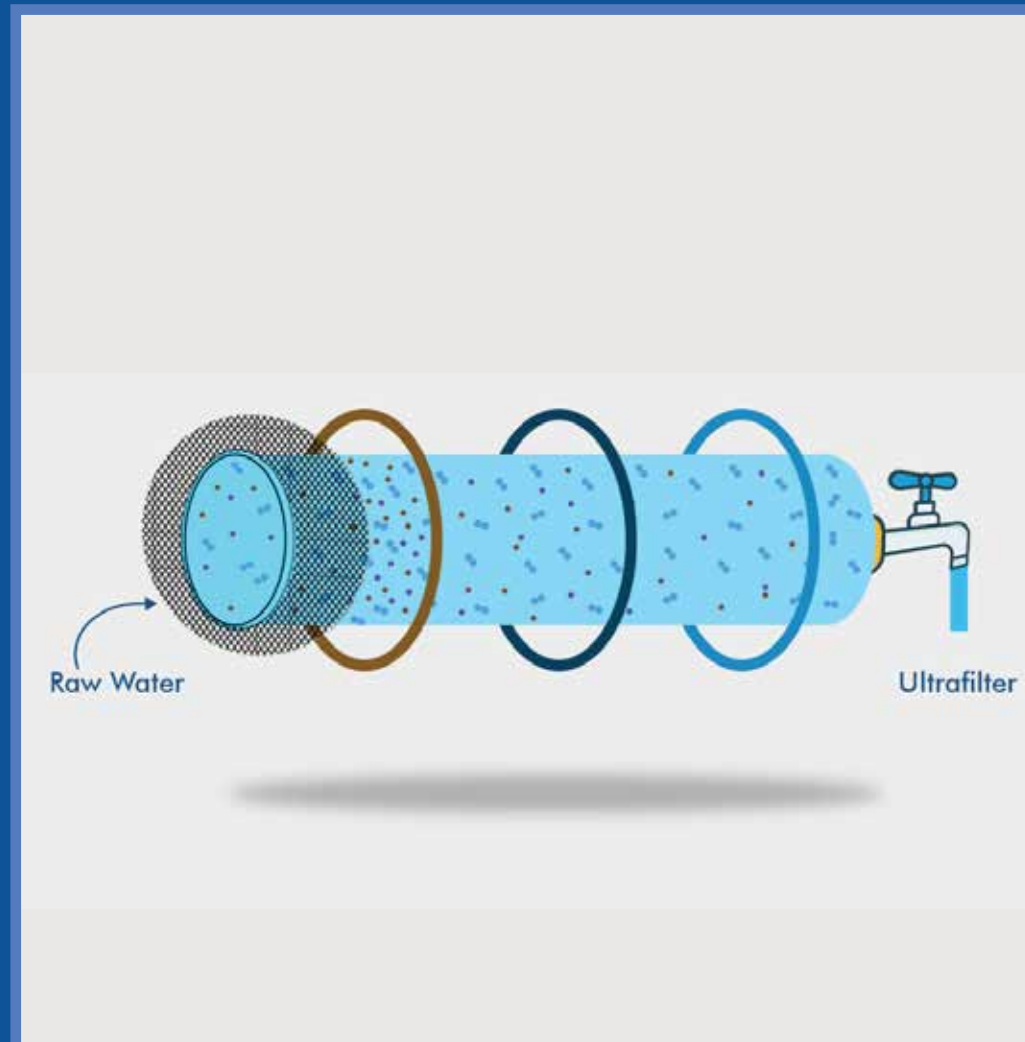

## Types Of Membrane

---

- Ultrafiltration Membrane - GraFiL
- Pervaporation Membrane
- ZLD- Membrane Distillation
- Oxygen Concentration Technology
- Membrane Decanter

# Membrane Distillation (MD)

The Specialty MD membrane act as selective barrier which allows water to transfer through it.

## Application

- Juice Concentration
- Salt Concentration
- Cooling tower blowdown treatment
- Desalination

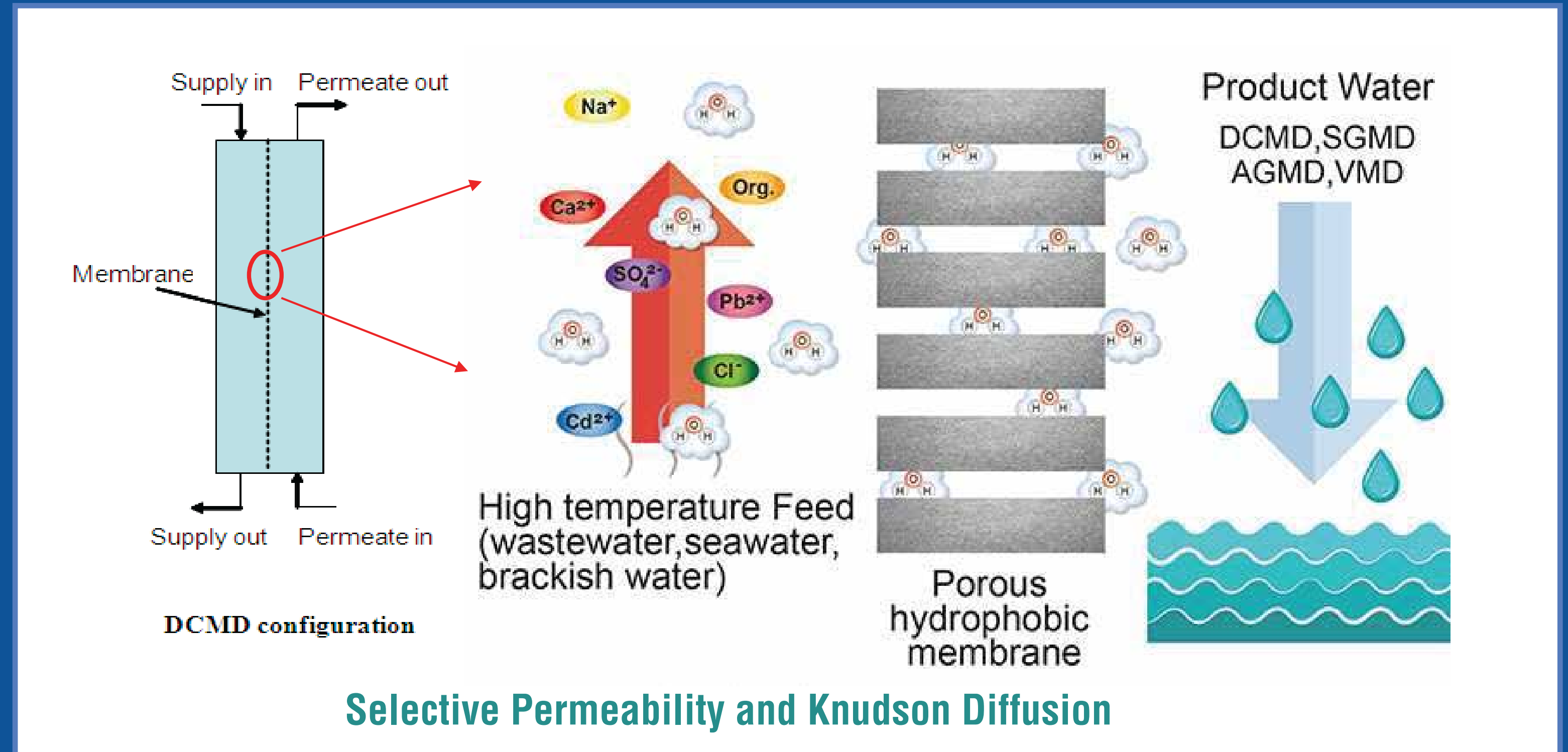

**Membrane Distillation (MD) is a separation using micro-porous hydrophobic membrane**

# Pervaporation (PV)

---

The Specialty PV membrane act as selective barrier which allows desired component to transfer through it.

Separation of component is based on difference in transport rate of individual component through membrane

## Application

- Solvent Dehydration
- Azeotropic Distillation



# Grafil Ultrafiltration Membrane

Membrane filtration in which hydrostatic pressure difference across semi-permeable porous membrane separates physical impurities from solution CDMS UF/ NF membrane are capable of separating substances at low pressure making them low energy consumption membrane

## Application

- Water treatment
- Milk Concentration
- RO water Pretreatment
- Pigment separation

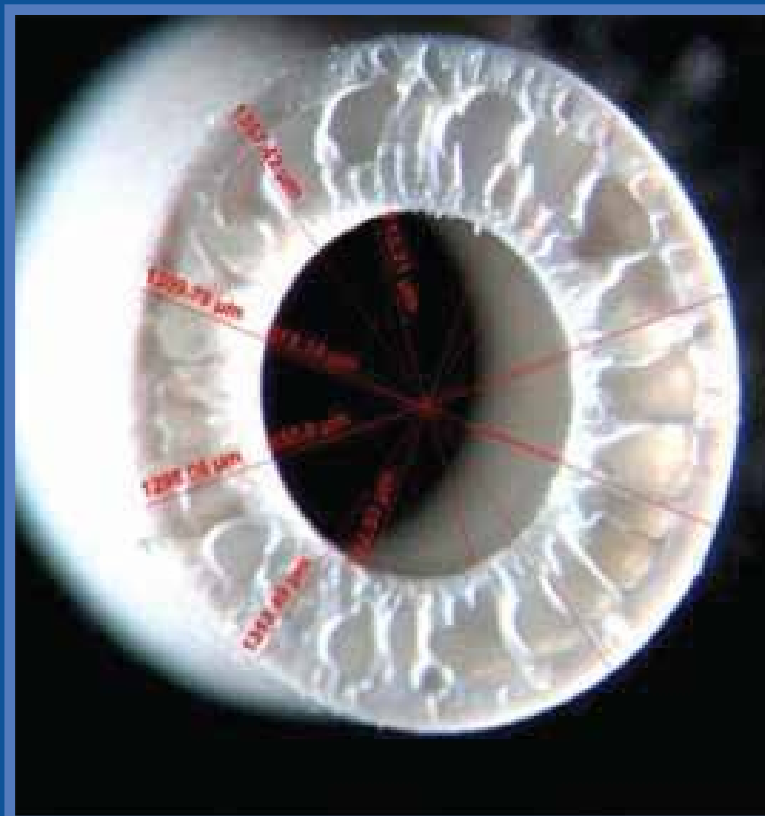

Hollow Fiber



# PolyNorbit – Performance Case Study

- The Pigment Recovery and COD load reduction in effluent treatment plan

Sr. No.	Customer	Sudarshan Chemical
1	Location	Mahad Maharashtra
2	Capacity	1320m <sup>3</sup> /d
3	Pigment Concentration	1100ppm
4	Commissioned	Jan28, 2020
5	Product	GRAFiL 6040*34 Nos.
6	Construction	2x30 m <sup>3</sup> /h Module
7	Filtration Mode	Cross Flow-10%
8	Water Recovery	90%
9	Product Recovery	99%



Blue Pigment - Lab

# Major Projects

---



**Recron Sdn. Bhd. Malaysia**  
5 MLD Ultrafiltration Water Treatment Plant



**Sudarshan Chemicals, Mahad**  
1.4 MLD Color Pigment Recovery Plant



# Journey So Far



**50+**  
Successful Turnkey  
Projects Installation



**500+**  
Clients Served



**12+**  
Industrial  
Segments



**10+**  
Patents



**30+**  
Products



**10+**  
Technologies



**6000+**  
Oxygen Concentrators  
Running



**6 Mn**  
Tata Swach Serving  
People Per Day



**100 Mn**  
Mask Delivered

# Clientele



# Collaborations

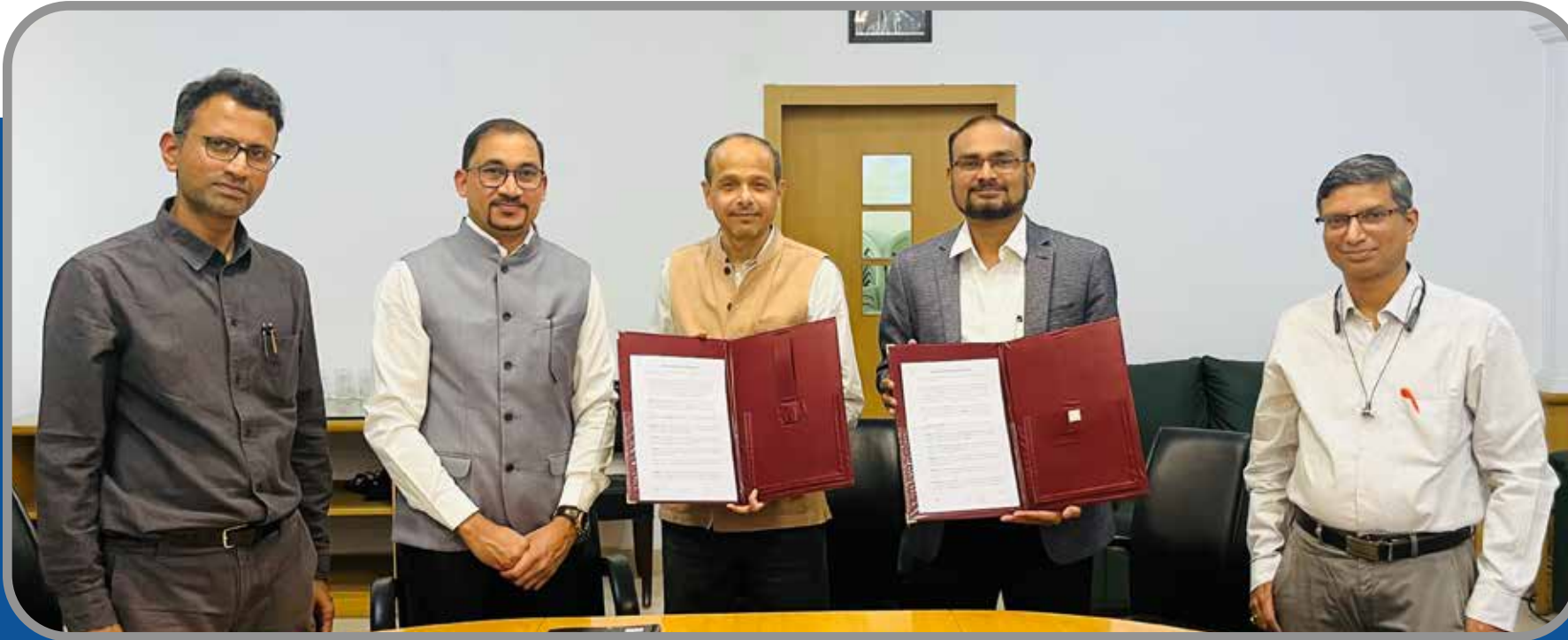

NCL Pune



IIT Guwahati



IIT Hyderabad

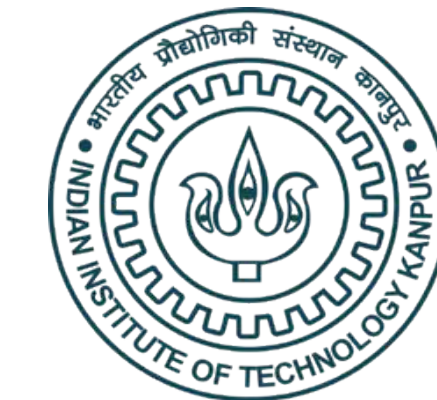

# Our R&D Network



**Dr. Dipankar Bandopadhyay**  
Professor, IIT Guwahati  
(Clean Energy - Fuel and Solar Cells)



**Dr. Amol Kulkarni**  
Scientist, CSIR-National Chemical Laboratory  
(Continuous Manufacturing and Scale-up)



**Dr. Srinivas Mettu**  
Senior Research Fellow, RMIT University  
(Bio-Technology)



**Dr. Akshai Kumar Alape Seetharam**  
Associate Professor, IIT Guwahati  
Catalysis (Heterogeneous and Homogeneous)



**Dr. Nageswara Rao Peela**  
Professor, IIT Guwahati  
(Biomass Conversion to Value Added Chemicals)

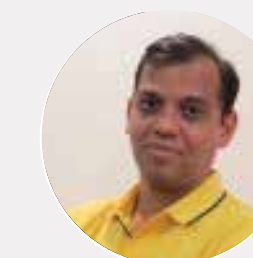

**Dr. Vivek Vitankar**  
Ph.D, ICT Mumbai & Director at FluidDimensions  
(Computational Fluid Dynamics)



**Dr. Sandip Patil**  
Ph.D, IIT Kanpur & Director, E-Spin Nanotech Pvt. Ltd.  
(Nano Technology)



**Dr. Uttam Manna**  
Associate Professor, IIT Guwahati  
(Bio-inspired Polymer Materials)



**Dr. Tapas K. Mandal**  
Professor, IIT Guwahati  
( Micro-Nano Technology for Energy Harvesting)

# Innovation



## Green Hydrogen

- Ammonia to Green Hydrogen (*IPR 2022121320000101*)
- Ethanol to Green H<sub>2</sub> (*IPR 202231020801*)
- Methanol to Green H<sub>2</sub> (*IPR 202231020801*)
- Bamboo to Green H<sub>2</sub> (*Patent under process*)
- Water Electrolysis (*Patent under process*)

## Carbon Capture

- Carbon Sequestration Technology to convert waste CO<sub>2</sub> to Nano Urea (*IPR 2022111520000101*)

## Green Chemistry

- Conversion of Glycerol to Lactic Acid (*IPR 202131057709*)
- Production of Levulinic Acid from Furfurol and Xylose Feedstock (*IPR 202131022345*)
- Preparing Levulinic Acid from C5 Furanic Compounds (*IPR 202031025327*)

## Other Technologies

- Turbulator to increase the Heat Transfer efficiency by 30% (*Patent No. 419403*)
- Membrane based system for Waste Water Purification and Desalination (*IPR 202021049371*)
- Membrane based Solvent Dehydration at low opex

A scenic mountain landscape with a hiker on a trail. The background features rugged, rocky mountains with patches of green grass and snow. A dirt path leads through the valley, and a hiker with a backpack is walking away from the camera. A small waterfall is visible on the left side of the image.

# Thank You

[www.chemdistgroup.com](http://www.chemdistgroup.com)

[info@chemdist.in](mailto:info@chemdist.in)

Tushar Wagh  
+91 9545557224

Dr. Sunil Dhole  
+91 9559213333